

ΩMEGA⁺

MOULDING CATALOG

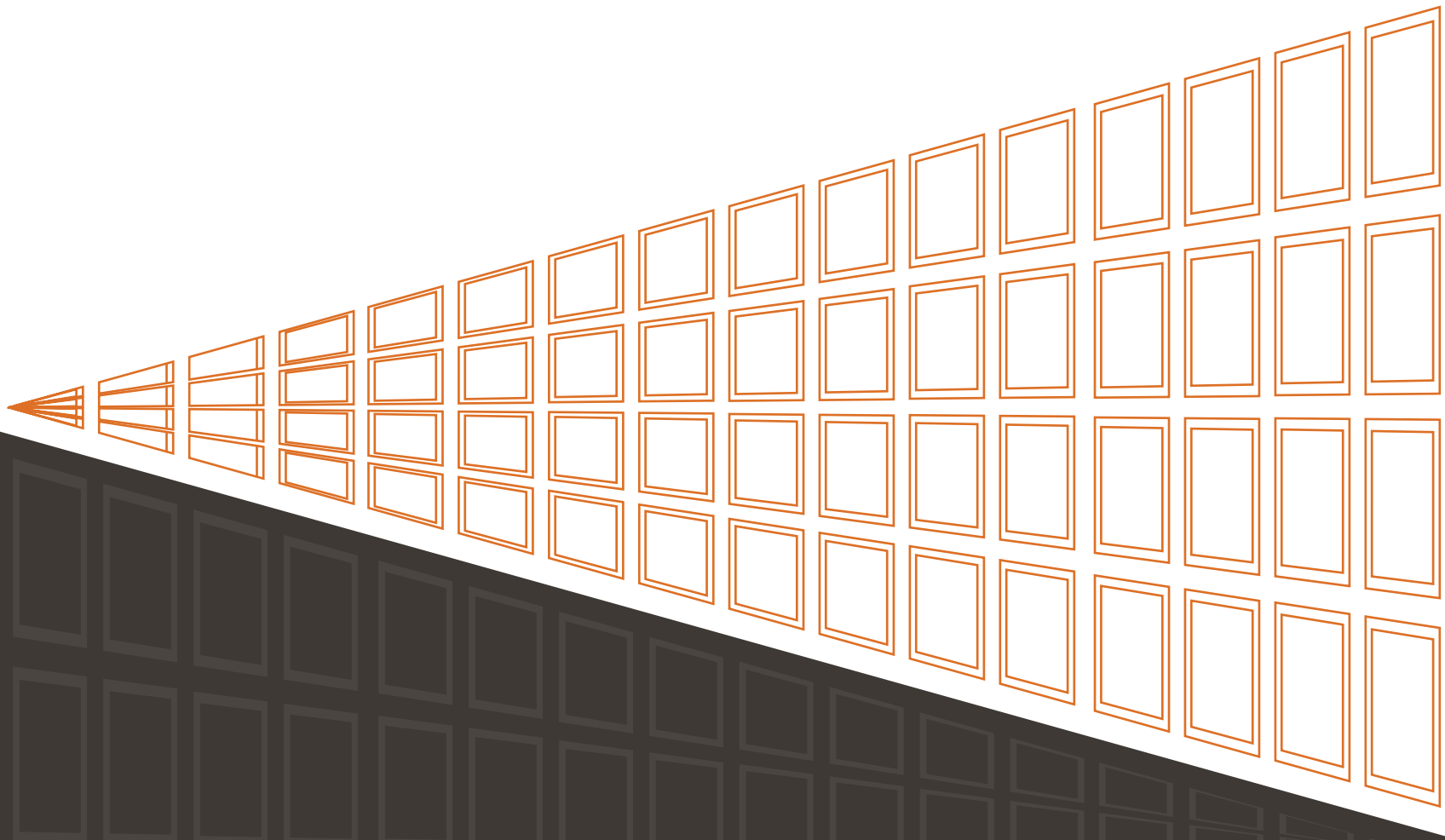

VALUE AND VISION

CONTENTS

	2	MODERN TRANSITIONAL
CLASSICAL	30	
	88	WOOD TONES
RUSTICS	118	
	126	COLORFUL
BLACK & WHITE	132	
	142	THE O ₂ COLLECTION
FLOATERS, LINERS & STRETCHERS	152	
	157	FLOATMATE
GALLERY FRAMES	165	
	183	RPS RECYCLED POLYSTYRENE MOULDINGS

Genuine olive wood veneer mouldings



83641 • 1 1/4" rabbet depth



83642



83643

Genuine olive wood veneer mouldings

83633

83637

83634

83638

83636

83640

83635

83639



83784

Genuine Daniela wood veneer



83783



83787



83786



83785



83778



83779

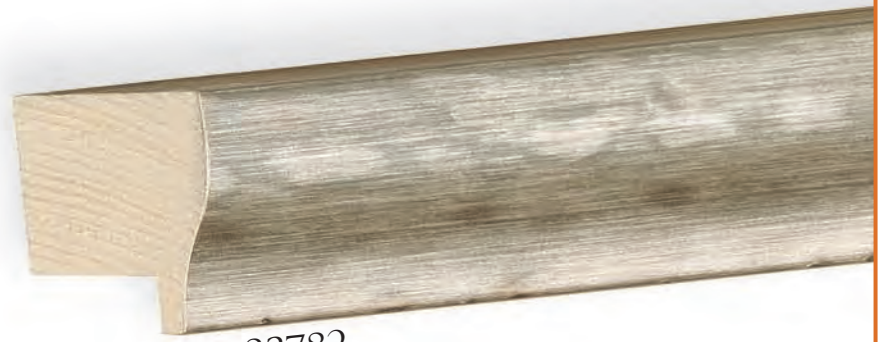

83782



83781

83780



Aluminum veneer mouldings



80813



80816



80815



80818



80814



80817



83695



83696



83694



83697



83698



83699



83650

83653



83652



83655



83654

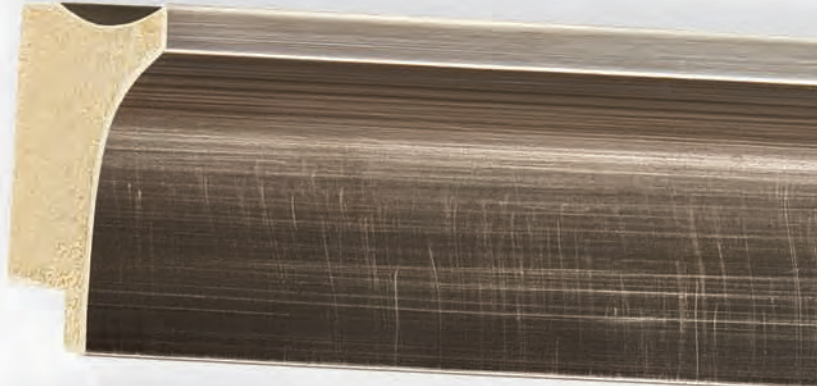

83651





1 5/8" rabbet depth • 83645

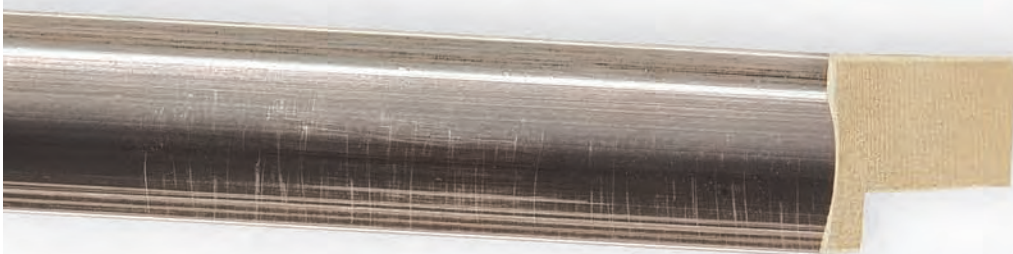

1 3/8" rabbet depth • 83648



1 5/8" rabbet depth • 83646



1 3/8" rabbet depth • 83649



1 5/8" rabbet depth

83644

83647



1 3/8" rabbet depth

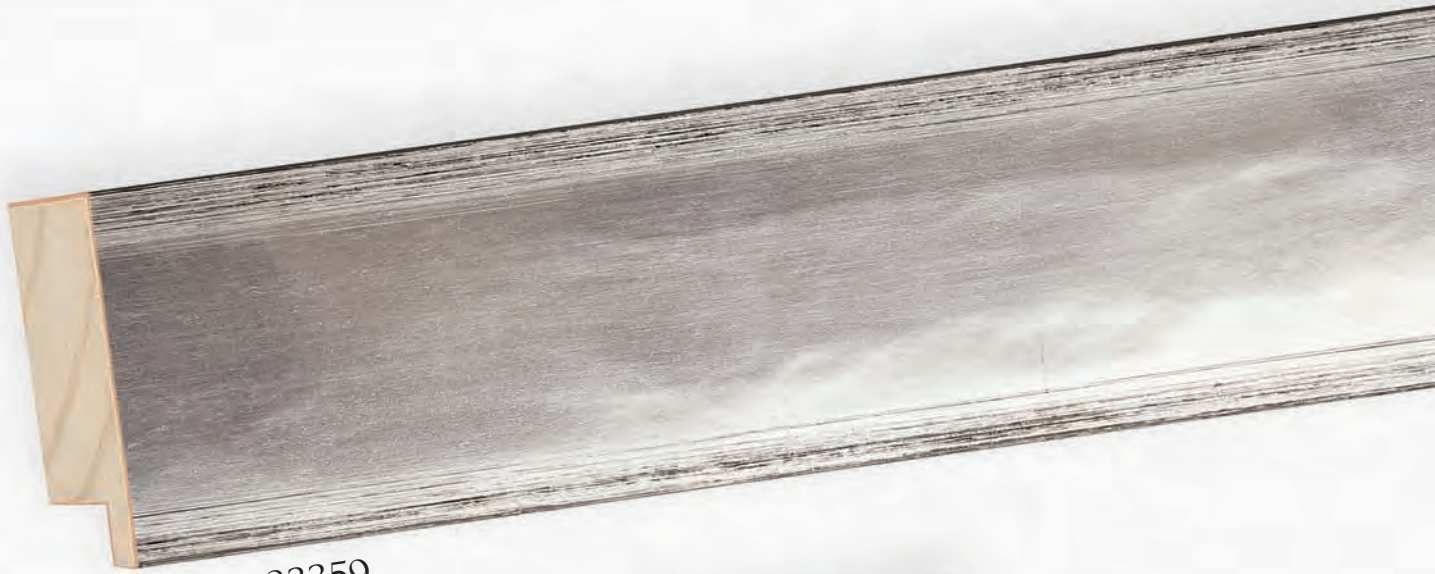

83359

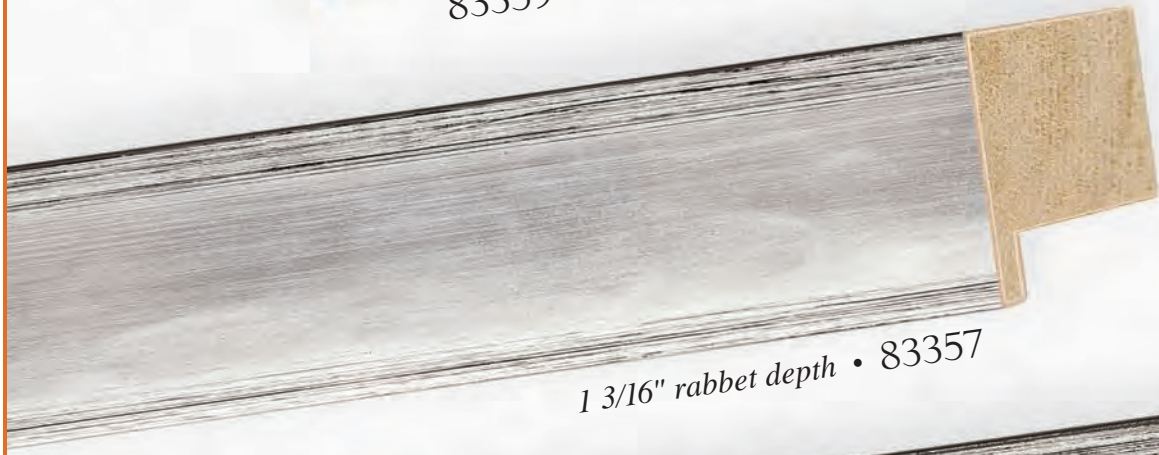

1 3/16" rabbet depth • 83357



83358

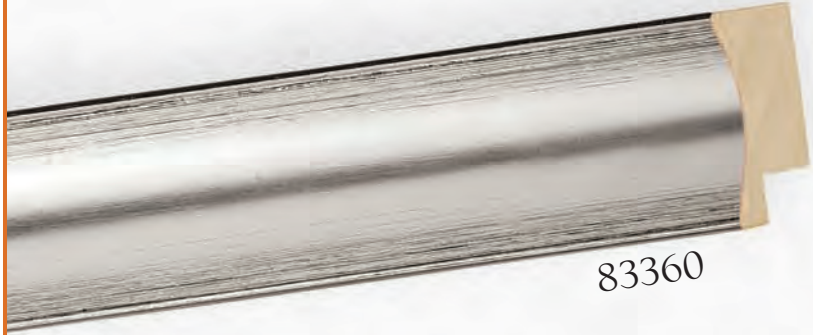

83360



83356

1 1/2" rabbet depth



83361

1 1/2" rabbet depth



80801



80802



80803

1" rabbet depth



80804

1" rabbet depth

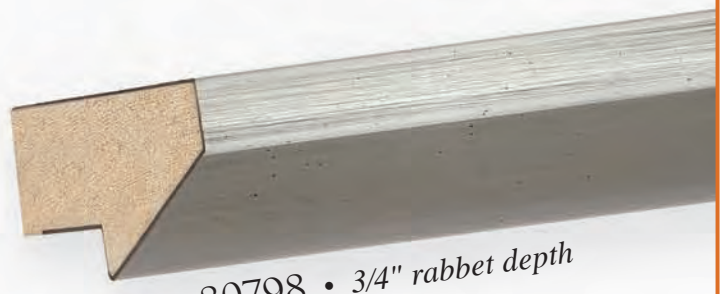

80798 • 3/4" rabbet depth



80800 • 3/4" rabbet depth



83758

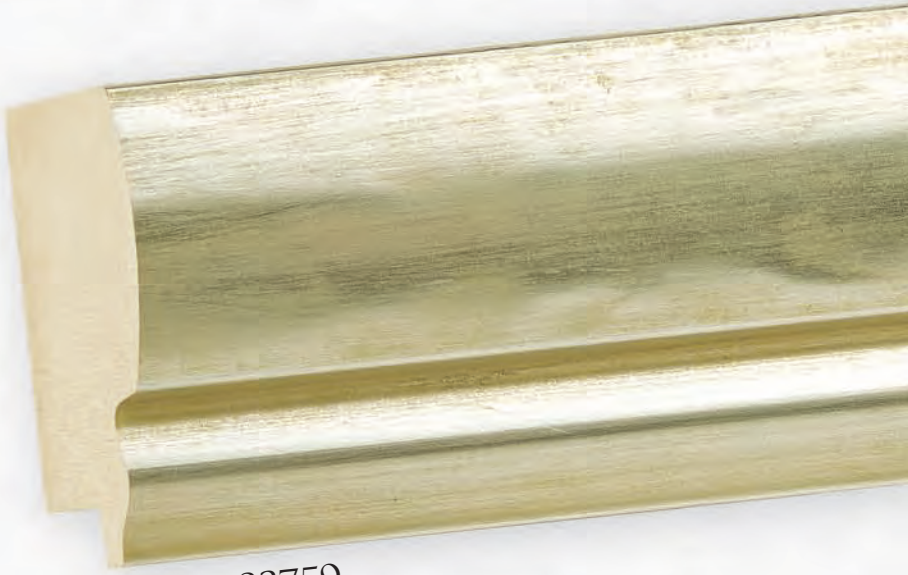

83759

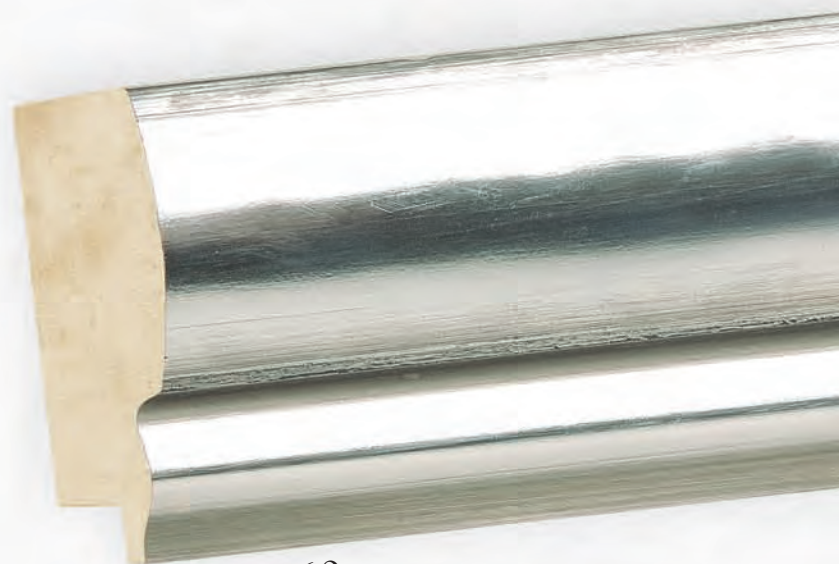

83760



83761



83762

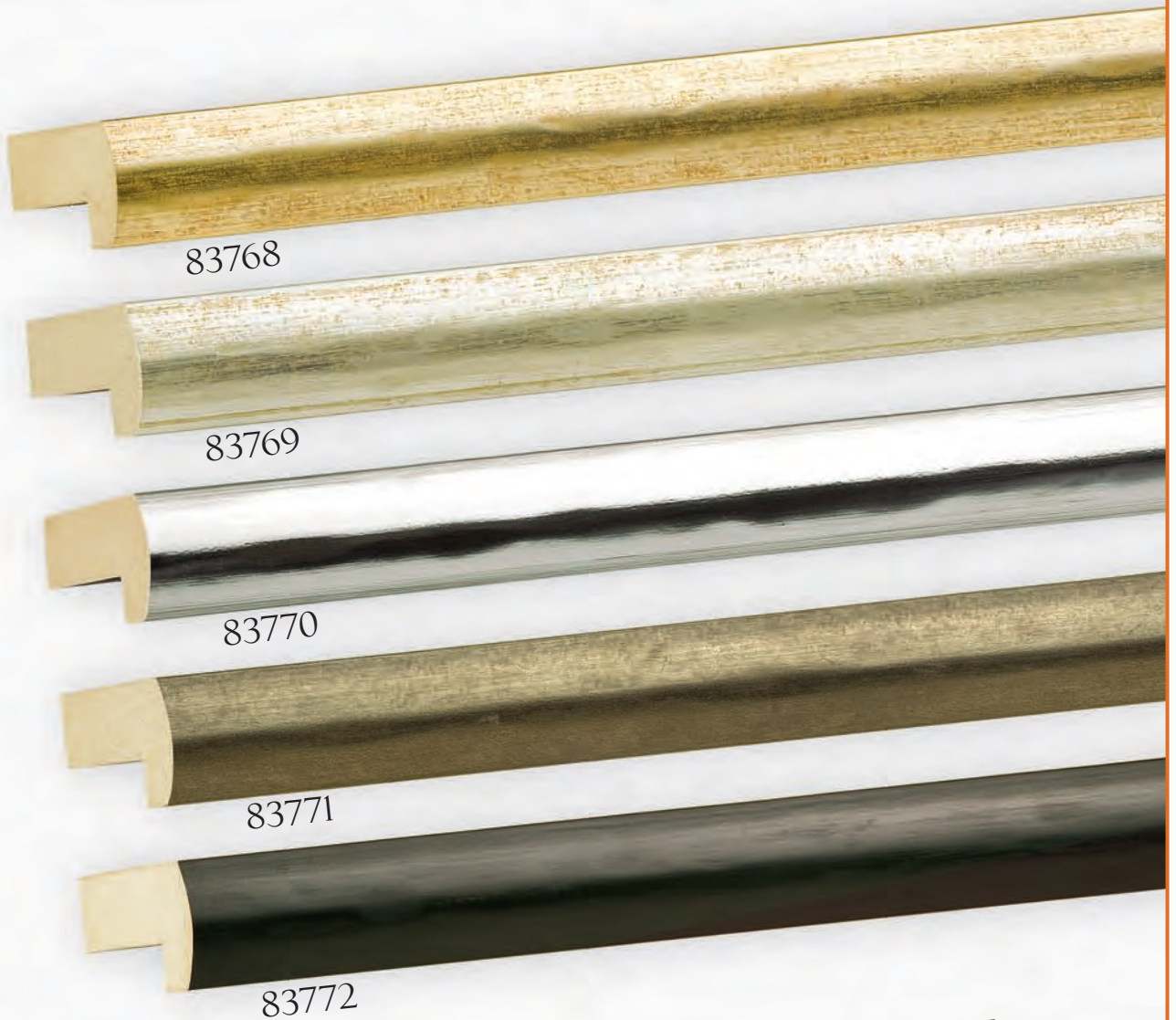

83768

83769

83770

83771

83772



83763

83764

83765

83766

83767



1 15/16" rabbet depth • 83878

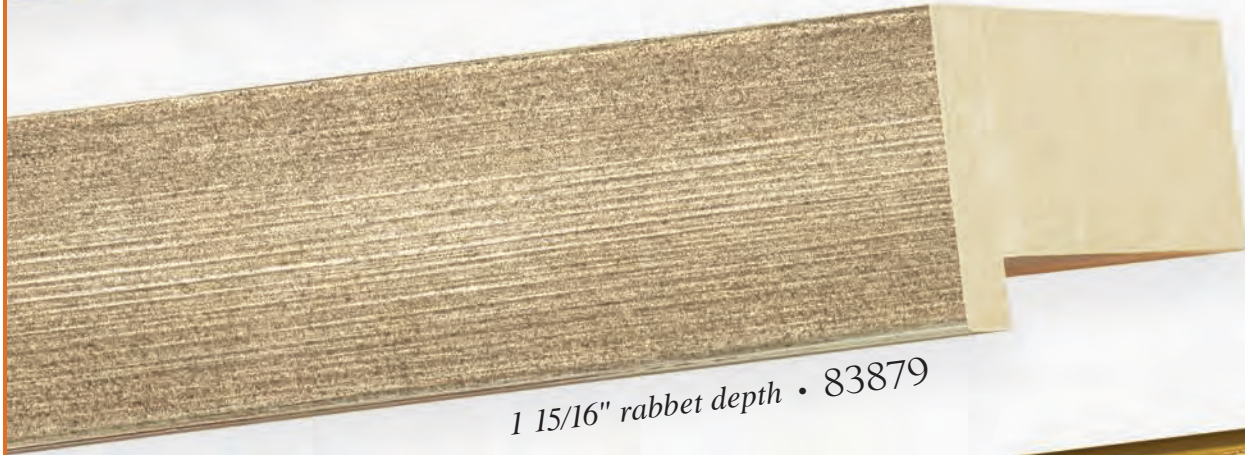

1 15/16" rabbet depth • 83879



83883

1 15/16" rabbet depth



83884 • *3/4" rabbet depth*



83885 • *3/4" rabbet depth*



83889 • *3/4" rabbet depth*



83881 • 1 15/16" rabbet depth



1 15/16" rabbet depth • 83882



1 15/16" rabbet depth • 83880



3/4" rabbet depth

83888

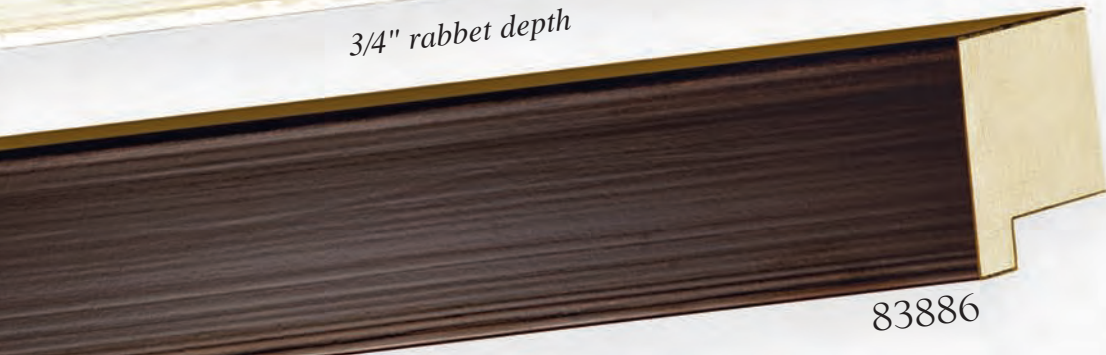

83886



83887

3/4" rabbet depth



83710



83711

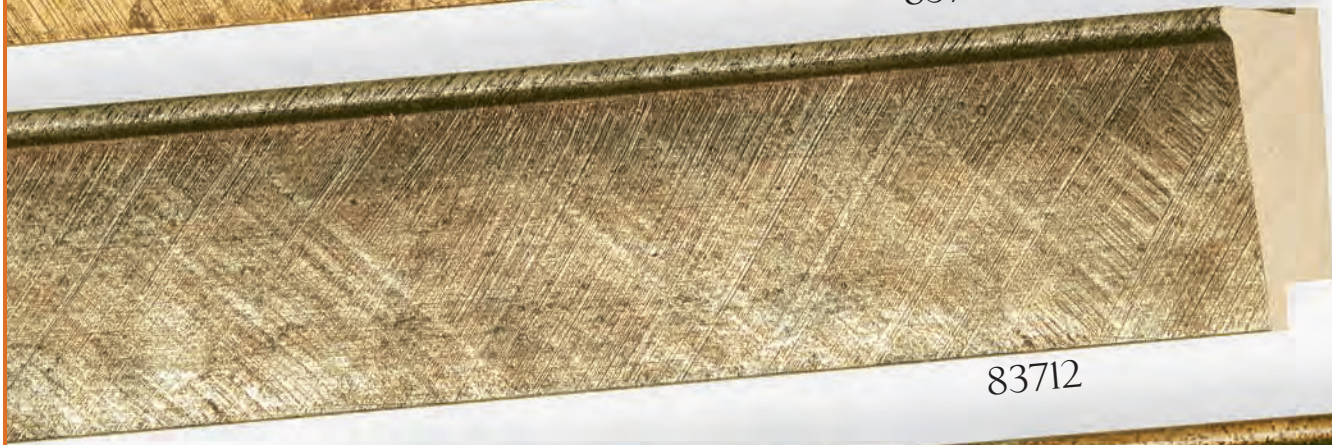

83712



83713



83714

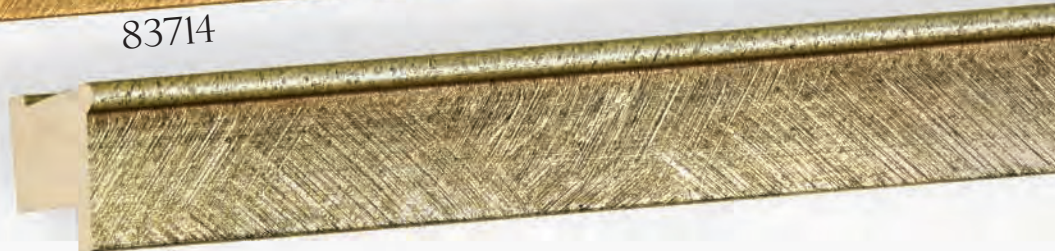

83715



83716



83717



83718



83719



83702



83703



83704



83705

High-Gloss Black



83706

High-Gloss White



83707



83708



83709

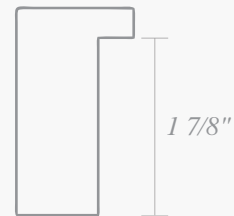

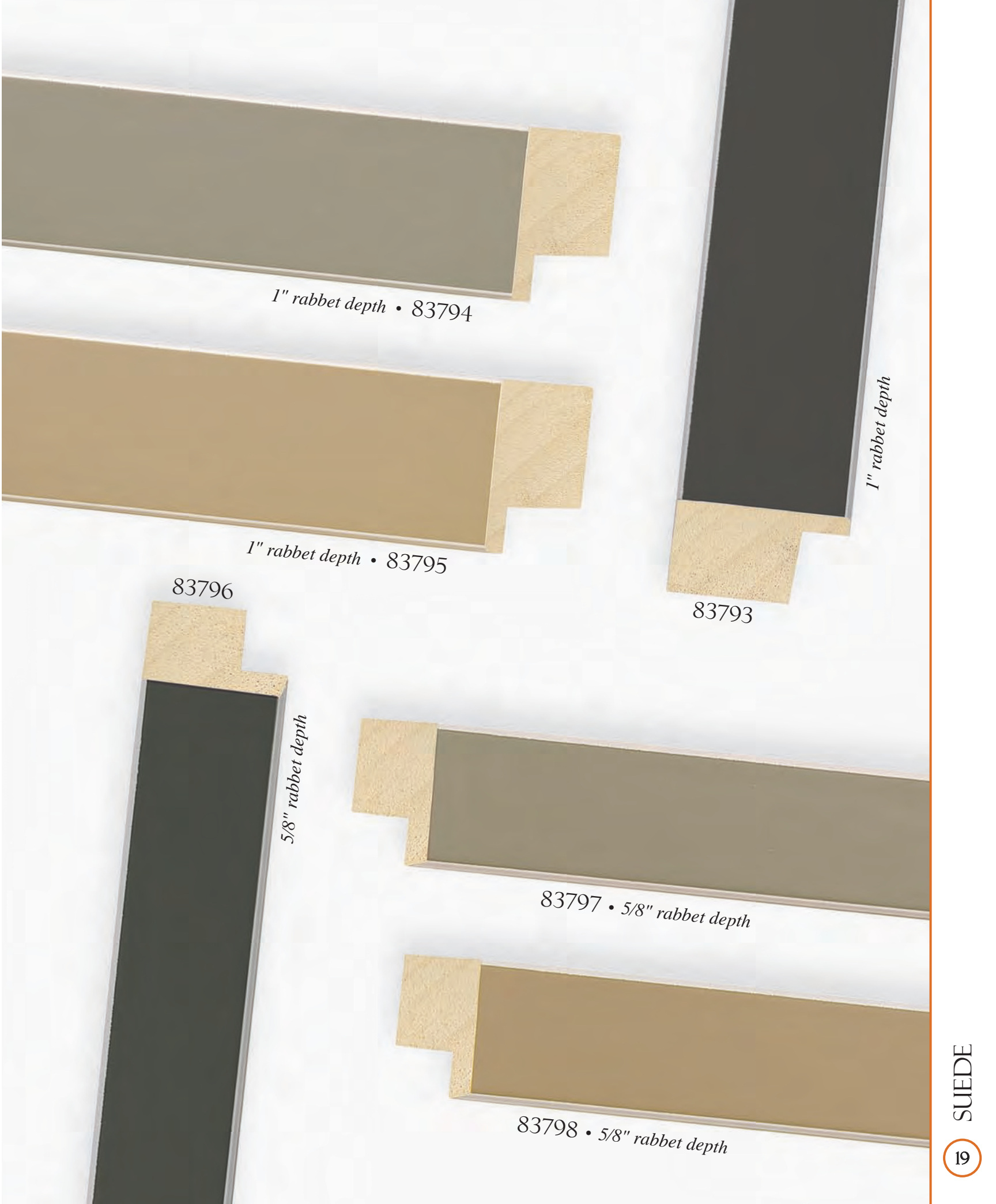

1" rabet depth • 83794

1" rabet depth • 83795

1" rabet depth

83796

5/8" rabet depth

83793

83797 • 5/8" rabet depth

83798 • 5/8" rabet depth



80482



80484



80483



80486



80488



80487



80498



80496



80407



80409



80408



80401



80413 • 1" floaters depth



1 1/2" floater depth • 83302



1 1/2" floater depth • 83303



1 3/4" rabbet depth • 83298



1 3/4" rabbet depth • 83299



83296



1" rabbet depth

83297

83300



1/2" rabbet depth

83301



1/2" rabbet depth



83391



83392



83389



83390

83387



13/16" rabbet depth

83388



13/16" rabbet depth



80881



80884



80878

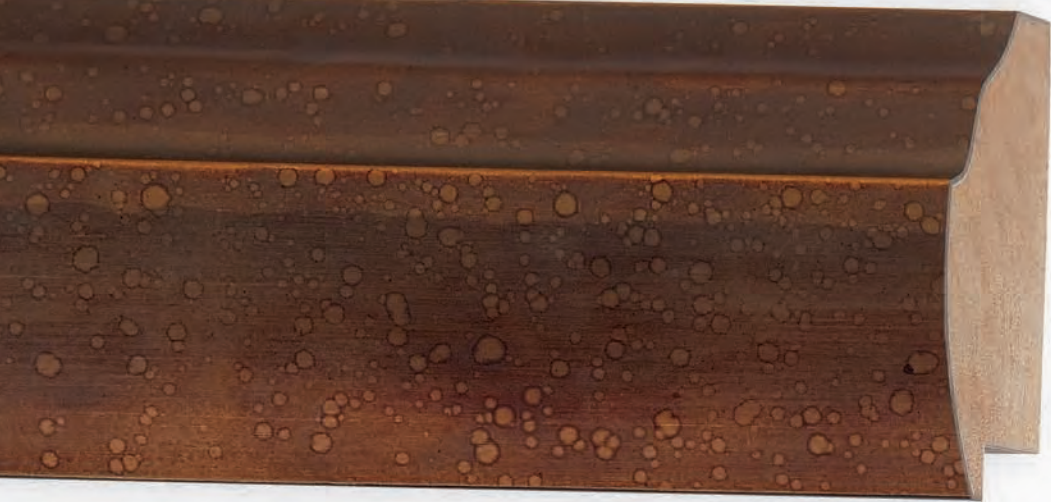

80879



80880

80886



80883



80882



80885



81000



81003



81006



80999



80998



81002



81001



81005



81004



83626

bronze with gold lip



83627

pewter with silver lip



83581 • *bronze*



83580 • *black*



83625

black with pewter lip



83582 • *scratched silver*



83583 • *silver*



80970



80971



80972



80977



80983



80978

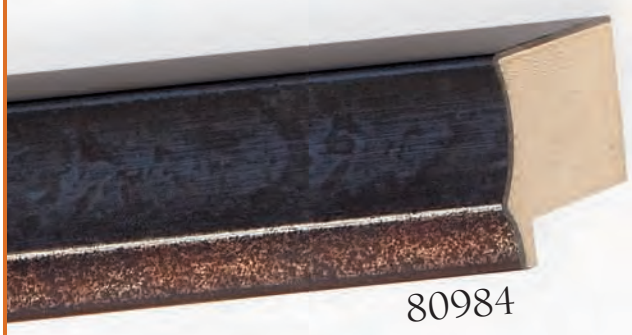

80984



80974



80975



80670



80666



80671



80667



80672



80668



PARKER



84247



84248



84245



84246

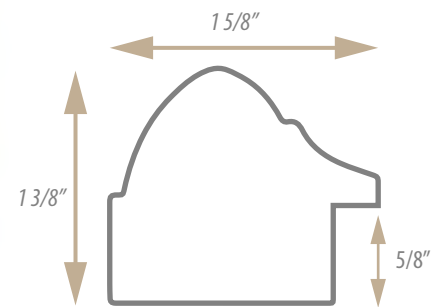

ΩMEGA⁺
MOULDING COMPANY

PARKER

The Parker Collection gives us two looks; a handsome traditional classic with warm furniture finishes, as well as Mid-Century modern elegance. This duality is well sought after in today's market, bridging traditional interior design motifs with more modern tastes in both art and home design. Art and home accessories play an important part in helping to fuse sleek modern home tech in our interior spaces with elements that are naturally more in tune with visual appeal and comfort.

Classics that can pull off modern will make Parker a new standard "go-to" for Picture Framers and designers alike. With the most popular trends in art and home decor staying consistent with these motifs, it delivers solutions for fine art (paintings, etchings, and drawings) to contemporary (photography, serigraphs, and graphic art.)

Parker is a great companion to **Carlyle** and **York** collection mouldings. Gold, silver, black and plum selections from each can be used together in a series, on the same wall, or combined in a single design.



△ Art (above): **Four Dancers**, Edgar Degas c.1899



◁ Classic Example

By keeping it simple, a lot can be achieved in creating an undeniable winning combination that hits on style points and fits into multiple interior design settings. Staying with a clean design can be key to allow the artwork's beauty to take precedence. Scale is also important; Parker's 1 5/8" width can accommodate small and larger work both physically and visually.

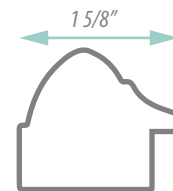

◁ Art (left): **No Gravity**, Lilo c.2022



The Parker Collection is handmade in Italy

MADE IN ITALY

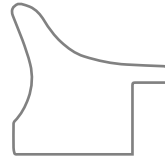

Carlyle

1 1/8" scoop profile with 9/16" rabbet



84256

84257

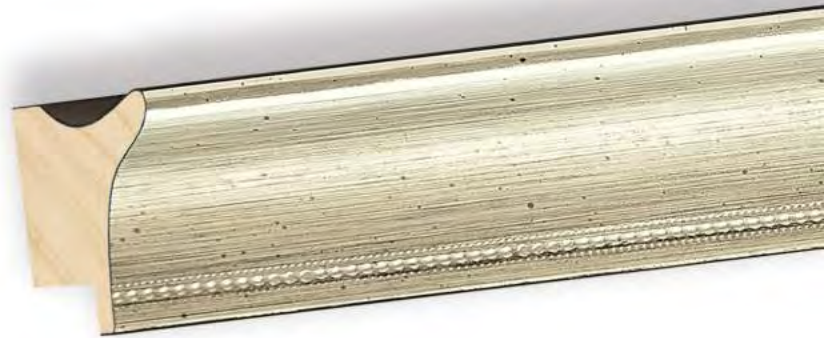

84259



84258



84260

ΩMEGA⁺
MOULDING COMPANY

Carlyle

Carlyle is a traditional profile with a modern twist. The luster and sparkle of modern gilding updates the look of the classic petite scoop adding a touch of sophistication. A delicate deboss is a contemporary treatment to the traditional beaded lip of classical mouldings of past eras. These subtle adjustments in design help streamline the overall look and convey a sense of fine workmanship.

The new styling allows the graceful scoop to be utilized on a wider range of artwork. The metallic finishes get a softer treatment, creating a lightness to the collection's palette in order to work with today's interior color schemes and art genres such as digital prints, illustration and color/black and white photography.

The collection can also be used to bridge styles within a setting where more traditional art and framing are present. Carlyle is naturally a lovely collection for collectibles, antiques, documents, drawings, etchings and fine art prints. Now, it can be shared with the art and home decor in today's market. Artists and designers will now have present-day classics at their disposal to create not only something new, but something that is timeless



Art (right): *Silver Eye, The Bell Bird*, Walter Lawry Buller c.1888 >



The Carlyle Collection is handmade in Italy



Classically Photogenic

At first glance, this collection may only seem traditional, but just look at what it can do for photography. What else can you use traditional profiles for? They call them classics for a reason.

AVA



84282 1 3/8" reverse scoop • white & metallic brush with navy blue crest



84281 1 3/8" reverse scoop • white & metallic brush with silver crest



84280 1 3/8" reverse scoop • white & metallic brush with gold crest

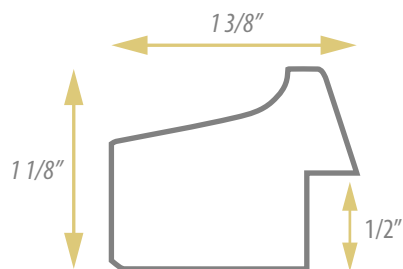

ΩMEGA⁺
MOULDING COMPANY

AVA

Ava is an elegant collection of three items that evokes a breezy coastal feel. The collection's aesthetic is designed to allow designers to introduce more sophisticated artwork into home settings with a clean tailored look, often seen in vacation homes.

Eternally popular coastal design, also known as 'beachy-chic', is recognized by the use of natural textures where materials such as rope, wicker, and driftwood are commonly employed within the setting. Shades of white, watery hues and white washed wood and fabrics are popularly used in the fabrication of furniture, home accessories and artwork.

Ava's white brushed finish carries the collection into this style category, setting the mood with a clean and airy sensibility. The brush lines are streaked with shimmering highlights that cast reflection from light to dark to deliver its textural dynamic. Accented on the crest with crisp gold (84280), silver (84281), and navy blue (84282); a nod to the nautical Ralph Lauren coastal home design palette popularized worldwide.



The collection's bright white finish was selectively curated for its compatibility with modern digital printing papers.



△ Art (above): *The Mirror*, Will Barnet c.1981



◁ Art (left): *Agave*, K. Nari c.2018



The Ava Collection is handmade in Italy

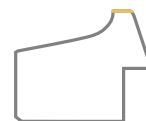

◁ Warm Tones, Cool Looks

One shouldn't hesitate to use brushed white mouldings for only cool color pairings. Warm hues, jewel tones, and bolder saturated colors can be cooled down with the airiness of white. Here, the gold accent on 84280 can bring it all together, pulling out the earthy browns and sunny yellows while complementing the bright blue and greens.

LOFT



84261



84262



84263

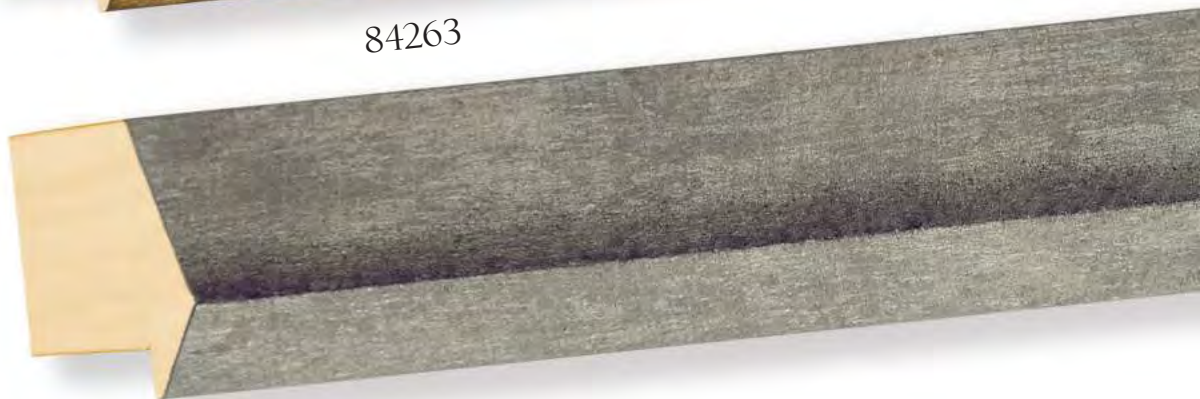

84264

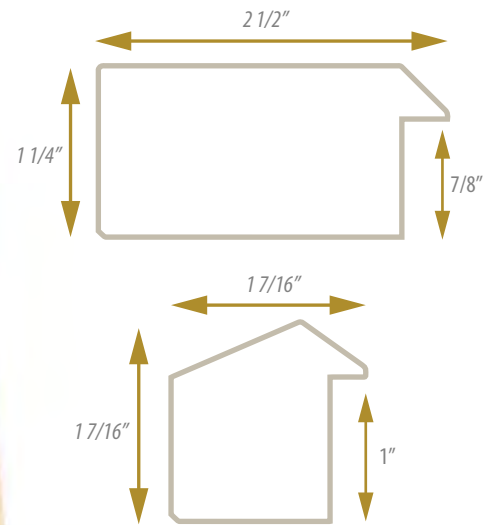

LOFT

Loft is a collection of pewter and gold items that have been toned and heavily textured to convey the look of raw, unrefined galvanized steel and bronze. This industrial look is produced to work with artwork and interior spaces in a variety of ways that enhance and reinforce characteristics within the aesthetics of each.

Industrial style focuses on the three components of strength, gravity, and architecture. The Loft Collection draws from these within its profile shape, colors, and proportion. Two geometric profiles were designed; the broad flat panel of 84261 (gold), and 84262 (pewter) are 2 1/2" wide and are ideal for large format framing as well as artwork that calls for bolder presentation. The second profile's sharp peak emphasizes the architectural lines a bit more in the 1 7/16" wide silhouette of 84263 (gold) and 84264 (pewter). The rough pitted metallic look gives the grouping its heavy feel, thus successfully uniting the elements to produce the intended design aspiration.

Loft mouldings are beautifully showcased on modern art pieces, exhibiting similar attributes of geometry, simple form and line, construction, abstraction, and dimension. Scale and size are also factored into designing with Loft. Large installation spaces can be magnificently outfitted by its bold architectural specs, making Loft great for hotels, galleries, showrooms, and open plan living spaces.

Art (right): *Oli Sobre Fusta*, Ricard Tovar c.2021 ▷



The Loft Collection is handmade in Italy

◁ In Great Shape

Geometric shapes aren't always as strict and cold as you would think. Even though they almost work on everything, the hard edges can be too defined on mouldings with opaque finishes. With Loft, you can expand the field of possibility and be creative in utilizing the collection for watercolors and oil paintings, or any other art application or subject matter that has blended pigments, softer lines, or subtle details. By way of its texture and variegated appearance, it can be used as an elegant solution for those pieces you may yet to consider.

◁ Art (left): *Les Coureurs*, Robert Delaunay c.1920

Volta



84271



84272



84269



84270



84273



84274

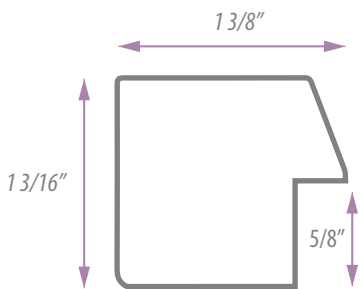

OMEGA⁺
MOULDING COMPANY

Volta

The Volta Collection is a neomodern collection, but it's timeless in that what you can design with it, is endless. Created to allow designers to produce elegant picture framing solutions, the collection uses soft muted hues that break away from neutral color schemes. This lends it to be used in a variety of interior environments as well as with more styles of art, as it blends warm and cool tones, and works simultaneously with both variegated and smooth textures. Geometric in shape, the profile can be easily integrated in modern and transitional interior design plans.

The overall look of Volta ranges from serene to dramatic. Softer subtle tones of silver in 84274 (fog grey), pewter in 84273, and champagne verdigris in 84271 (moss), invite the designer to explore more within the neutral palette. Meanwhile, the colorful contrast of 84269 (charcoal) uses black, copper, and oxidized silver; 84272 (blue) employs a color story of blues and violet upon gold, copper and pewter. Even gold, in 84270, (dark sand) is a visual treat surely to be used in any stretch of the imagination.

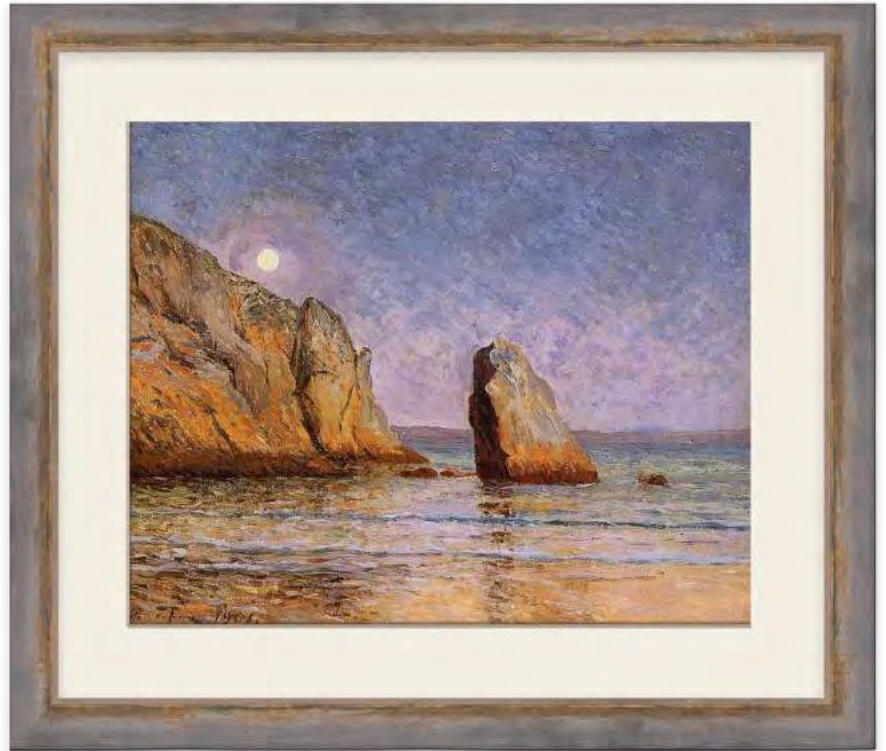

△ Art (above): *Moonrise*, Maxime Maufra c.1901



The Volta Collection is handmade in Italy

◁ A Finer Blend

With an attractive variety of color hues, textural tones and tinted metal patinas, Volta's unique mix of attributes works well on art from different eras. From the layered softness of impressionism (above), to more graphic illustrative work (left), this collection will inspire one's creative side to emphasize desired colors and details in the artwork that will elevate each piece to treasured status.



The beveled nose surrounding the artwork is gilded, creating a brightly edged border that helps to draw the viewer's focus toward the subject.

◁ Art (above): *Setting Intentions*, Duy Huynh c.2014



84276



84277

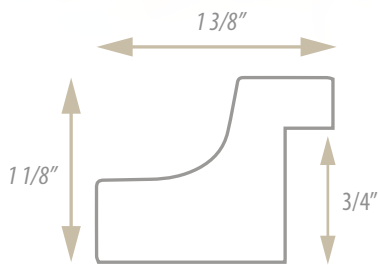

84278



84275



84279

Gio
OMEGA



Gio

The Gio Collection is a colorful and whimsical collection of five items that is truly transitional and dynamic. Soft metal patinas are featured, creating contrasts and interesting plays of shadow and light. There are numerous tonal subtleties within each finish, allowing a designer to try multiple samples within this collection for the same piece, all depending on the eye of the beholder. A deep reverse swan profile leads to a flat cap top that creates a reflective plateau surrounding the artwork.

Gio's overall aesthetic is tranquil and refined but can be used for dramatic effect when creativity strikes. Light and ethereal 84275 (white-silver), and 84278 (slate-violet), are brilliant and soft, appealing for designing with pastel color palettes and impressionist style works. A blend of warm and cool is displayed on 84276 (beige-silver) with a terracotta weathered finish on silver. The earthy contrasts of 84277 (brown-gold) is more dramatic as is the stunning 84279 (black-gold). This collection is sure to be a favorite for designers who have an eye for the unique.

Art (right): *Breaking The Cycle*, Duy Huynh c.2020 ▷



The Gio Collection is handmade in Italy

◁ Multi-Use, Multi-Hues

While designing with Gio, one must know ahead of time to "expect the unexpected." There's something about those hues and reflections that makes one try them all. Whether you intend to be imaginative or practical, you'll find yourself in full designer mode. The finish is somewhat reminiscent of Venetian plaster or fresco where, depending on the light, can cast a different color on second glance. This will lead to innovative color decisions on mat board choices and for the more creative-minded, you will express your design skills to the fullest.

☆ Gio is a nice companion to the Volta Collection.

◁ Art (left): *Anemone*, William Morris c.1876

GEHRY

OMEGA⁺
MOULDING COMPANY

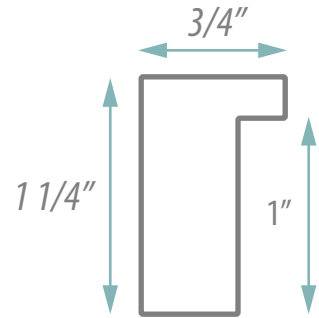

84283

84284

84285

84286

84287



TRENDSETTER
TrendSetter Program Collection

GEHRY



Gehry is a classic modern collection with an industrial aesthetic, rendered in the textural complexity of grinded metal on a geometric profile. Plays of light are produced in the radial swirls and streaks and is the star of the show, introducing a new and unique finish for picture framing artwork in a variety of interior design schemes.

Five finishes equally showcase the coolness and warmth of metal; silver (84283), champagne (84284), and pewter (84285) are beautiful accompaniments to black and white photography, etchings, graphic art, and art with neutral tones. Copper (84286) and gold (84287) bring life to more colorful media and modern art, color photography, lithographs, and watercolors, as well as transitioning many genres of art into a single design theme, such as gallery walls, and framing art collections. Gehry's 1" rabbet allows for framing works on canvas and dimensional work requiring spacer and shadow box applications.

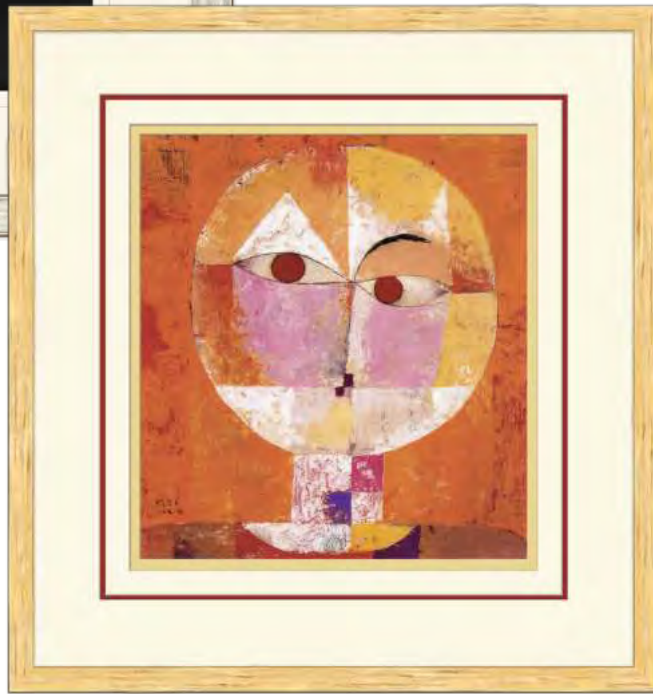

△ Art (Top left):
Butterfly (pigment photograph)
Mark Shaw, c.1950

◁ Art (left):
Senecio
Paul Klee, c.1922



The Gehry Collection is handmade in Italy

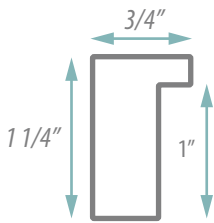

Walt Disney Concert Hall · Los Angeles, California



◁ Brightly Inspired

The Gehry collection pays homage to the beautiful polished steel architecture of Frank Gehry and the appealing brilliance of grinded metal artwork.