

# ΩMEGA<sup>+</sup>

## QUALITY FRAMING PRODUCTS

MAT BOARD & FOAM BOARD	1
GLASS, ACRYLICS & MIRRORS	2
FLETCHER JOINING & FITTING SUPPLIES, TOOLS & EQUIPMENT	3-4
GLASS, ACRYLICS & MIRROR CLEANING MATERIALS, V-NAILS	5
PICTURE WIRE, FRAME HARDWARE, HANGING ACCESSORIES	6-8
CUTTING EQUIPMENT, BLADES & ACCESSORIES	9
MOUNTING SUPPLIES, CONSERVATION TAPES & ADHESIVES	10-13
FINISH TOUCH-UP & FILLERS	14
JOINING & FITTING SUPPLIES, TOOLS & EQUIPMENT	15
OTHER SUPPLIES	16
PACKAGING MATERIALS & SUPPLIES	17
PETERBORO MATBOARDS	18-22
INSTRUCTION & REFERENCE MEDIA	23

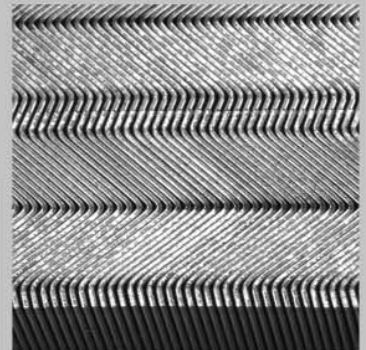
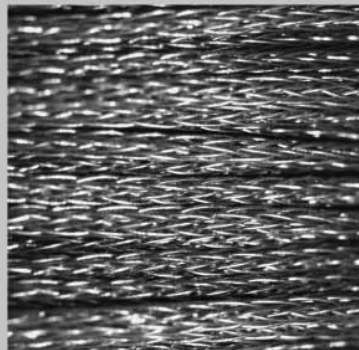
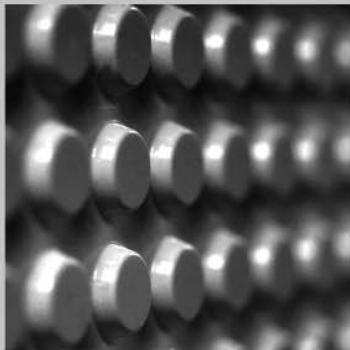

## Hampton

### Omega's Value Mat Board Line 32" x 40"

Quality mats for contract work

#### Cream Core Contract Mat Line

- Soft cream colored core provides a clean, crisp bevel.
- All components are buffered with calcium carbonate to an alkaline pH.
- Evenly toned surface papers available in a variety of popular, high volume colors.

<u>Item</u>	<u>Color</u>	<u>Item</u>	<u>Color</u>
H3000	Ultimate White	H3302	Cricket Green
H3001	Plain White	H3303	Sea Foam
H3002	Old White	H3304	Sage
H3003	Bone	H3400	Dark Chocolate
H3004	China White	H3401	Light Sand
H3005	Sand Stone	H3402	Pebble
H3099	Natural Parchment	H3403	Dolphin
H3100	Jet Black	H3405	Espresso
H3101	Shell	H3406	Plaster
H3102	Deep Grey	H3407	Concrete
H3103	Flagstone	H3408	Hazelnut
H3104	Blue Grey	H3409	Putty
H3200	Navy Blue	H3410	Desert
H3202	Slate Blue	H3500	Red
H3203	Royal Blue	H3501	Wine
H3300	Pine	H3502	Fire
H3301	Slate	H3600	Straw

#### Suede 32" x 40" White Core Matboard

- Specially developed to have a rich look and feel of the imported suede known so well in today's matboard market.
- Made with high quality whitecore this OEM product will meet your needs for both price and appearance.

<u>Item</u>	<u>Color</u>
HS7600	Coal Suede
HS7601	Cobalt Suede
HS7602	Doe Suede
HS7603	Golf Green Suede
HS7604	Burgundy Suede
HS7605	Red Suede
HS7606	Fawn Suede
HS7607	Dark Blue Suede

### Full line of PETERBORO **MATBOARDS**

- Including Museum Rag, Conservation, White Core, Black Core, Regular Core and Suede Mat Boards Available.
- See pages 18 - 22 or our Peterboro specifier for details.

## Bienfang® First Quality Foam Board



#### Regular Foam Board

Item #	Size	Box Qty
RFB2436	3/16" - 24" x 36"	25
RFB3240	3/16" - 32" x 40"	25
RFB4060	3/16" - 40" x 60"	25
RFB4896	3/16" - 48" x 96"	25
TFB3240	1/8" - 32" x 40"	25

#### Heat Activated Foam Board (Single-Step)

Item #	Size	Box Qty
SFB2436	3/16" - 24" x 36"	25
SFB3240	3/16" - 32" x 40"	25
SFB4060	3/16" - 40" x 60"	25

#### Acid-Free Foam Board

Item #	Size	Box Qty
AFB3240	3/16" - 32" x 40"	25
AFB4060	3/16" - 40" x 60"	25
AFTB3240	1/8" - 32" x 40"	25

#### Black on Black Acid-Free Foam Board

Item #	Size	Box Qty
BBFB3240	3/16"-32" x 40"	25
BBFB4060	3/16"-40" x 60"	25

#### Cotton Rag Foam Board

Item #	Size	Box Qty
CRFB3240	3/16"-32" x 40"	25
CRFB4060	3/16"-40" x 60"	25

## Quality Glass Products

### Clear Select

2 mm Float Glass

Washed, polished, and paper interleaved for instant usability.

Style	Size	Lites Per Box
RG810	8 x 10	90
RG8511	8.5 x 11	77
RG1114	11 x 14	47
RG1216	12 x 16	38
RG1418	14 x 18	29
RG1620	16 x 20	23
RG1824	18 x 24	17
RG2024	20 x 24	15
RG2228	22 x 28	12
RG2430	24 x 30	10
RG2436	24 x 36	8
RG2632	26 x 32	9
RG2636	26 x 36	8
RG2836	28 x 36	8
RG2838	28 x 38	7
RG3032	30 x 32	8
RG3036	30 x 36	7
RG3040	30 x 40	6
RG3240	32 x 40	6
RG3648	36 x 48	4
RG4060	40 x 60	3

### Clear Select

2.5 mm Float Glass

Washed, polished, and paper interleaved for instant usability.

Style	Size	Lites Per Box
RGH3240	32 x 40	6
RGH3648	36 x 48	4
RGH4060	40 x 60	3

### Non Glare

2 mm single-side micro-etched non-glare float glass.

A truer clarity than double side etched non-glare glass.

Washed, polished, and paper interleaved for instant usability.

Style	Size	Lites Per Box
NG1620	16 x 20	23
NG2024	20 x 24	15
NG2228	22 x 28	12
NG2430	24 x 30	10
NG2436	24 x 36	8
NG3040	30 x 40	6
NG3240	32 x 40	6
NG3648	36 x 48	4
NG4060	40 x 60	3

### Schott Mirogard<sup>®</sup> Anti-Reflection Water White Glass

Provides truest clarity and color presentation of your artwork. The only Anti-Reflection coated Water White Glass ever developed. Fingerprints cannot permanently penetrate Anti-Reflective coating. Washed, polished, and paper interleaved for instant usability. Simple Cleaning. No need for specialty glass cleaners.

Style	Size	Lites Per Box
MG2436	24 x 36	4
MG3240	32 x 40	3
MG3648	36 x 48	2
MG4060	40 x 60	3
MG4869	48 x 69 <sup>5/8</sup>	2

1 Box Minimum order on all Glass.

### Schott Mirogard<sup>®</sup> Preservation

Museum Conservation Quality Water White Glass.

Anti-Reflection with UV Protection.

The greatest color and clarity in UV protection glass available.

Fingerprints cannot permanently penetrate Anti-Reflective coating.

Washed, polished, and paper interleaved for instant usability.

Simple Cleaning. No need for special glass cleaners.

Style	Size	Lites Per Box
MGP2436	24 x 36	4
MGP3240	32 x 40	3
MGP3648	36 x 48	2
MGP4060	40 x 60	3
MGP4869	48 x 69 <sup>5/8</sup>	2

### High Quality 1 1/4" Beveled Mirrors



- All Mirrors are washed, polished and ready to frame.
- All Mirrors are individually boxed.
- Mirrors are 1/4" thick.

Item #	Size
BVM810	8 x 10
BVM1620	16 x 20
BVM2024	20 x 24
BVM2228	22 x 28
BVM2430	24 x 30
BVM2436	24 x 36
BVM3040	30 x 40
BVM3248	32 x 48
BVM3648	36 x 48
BVM1860	18 x 60
BVM2460	24 x 60

### Premium Clear Acrylic

- Acrylite with excellent optical quality specifically for framing.
- Sheets are guaranteed defect free.
- 3mm thick (.118")

Item #	Size	Qty/box
PXC3240	32 x 40	3 sheets
PXC4060	40 x 60	2 sheets
PXC4896	48 x 96	1 sheet

### Plexiglass OP-3

- UV protective acrylic sheet for conservation framing.
- Filters out 98% of damaging ultraviolet rays.
- 3mm thick (.118")

Item #	Size	Qty/box
PXUV4060	40 x 60	1 sheet
PXUV4896	48 x 96	1 sheet

**Fletcher FlexiMaster Point Driver (Green)**

- Easy-to-load magazine.
- Tension can be adjusted to suit the framer and specific wood density.
- Steady performer. Fires one point at a time without jamming or double feeding.
- Uses flexible framers points.

Item # **FL07700**

**Fletcher Flexible Framers Points**

- 5/8" long. Approx 250 points per stack.

Flexible Points for manual point drivers.  
3700 points per box. Item # **FL08955**

Flexible Points for pneumatic driver.  
12,000 points per box. Item # **FL08995**

**Fletcher FrameMaster Point Driver (Black)**

- Precision firing; no jamming or double feeding.
- Spring-adjusted firing power to match wood density.
- Uses FL08950C framers points.

Item # **FL07500**

**Fletcher Framers Points**

- 5/8" long. Approx. 100 points per stack.

FrameMaster points for manual point drivers.  
3000 points per box. Item # **FL08950C**

FrameMaster Points for pneumatic driver.  
12,000 points per box. Item # **FL08985**

**Fletcher MultiMaster Point Driver**

- Eliminates the need for glue, nails, or off-set clips. Ideal when fitting stacked frames, liners, canvas, and complex fitting jobs.
- A spring adjustment allows you to adjust for wood density.
- Uses FL08975 MultiMaster points.

Item # **FL07800**

**Fletcher MultiPoints**

- 1/2" long (approx. 3000 per box)

Item # **FL08975**

**Fletcher Gold Tip® Glass Cutter**

- Features "Classic" contoured comfort grip and ball end handle style.

Steel Wheel 120° Traditional cast handle.

Item # **FL01118**

Carbide Wheel 120° Traditional cast handle.

Item # **FL01240**

**Pneumatic FrameMaster® & FlexiMaster®**

- Fires tight and flat to the surface providing superior holding power.
- Used with Framer's Points in stacks of 250 points and Flexible Framer points in stacks of 425 points.
- Designed for left or right-handed use
- No "pull-back" required; slide point driver along moulding for continued firing
- Less shock to the frame than manual point drivers
- Ergonomically designed trigger eliminates hand fatigue
- An industry standard for production framing.

Pneumatic FrameMaster Item # **FL07300**

Pneumatic FlexiMaster Item # **FL07400**

**Framers Points**

- 5/8" long. Approx. 100 points per stack, 3000 points per box for manual point drivers.

Item # **FP300**

- Pneumatic FrameMaster Points (3,000/box)

Item # **FP1200**

**Flexible Framers Points**

- 5/8" long. Approx 250 points per stack.

3,000 points per box.

Item # **FP500**

**Fletcher PullMate™**

- Specifically designed to remove Fletcher Framer's Points from wood frames.
- Raised grip helps protect framing materials.

Item # **FL09517**

**Fletcher Scoring Tool**

- Two cutting tips with precision ground edges for scoring of acrylics.

Item # **FL05111**

**Fletcher 3100 Series Cutting Machine**



This machine makes easy work of scoring Gatorboard, hardboard, matboard, and foamboard, up to 1/2" thick. Scores glass and plastic up to 1/4". The "Pillar Post" design allows you to quickly switch blades for cutting glass, plastic, mat board or hardboard.

Item # **FL04715** 63" cutting capacity

**Fletcher Measuring Stop for 3100**



• Measuring Stop for Fletcher 3100.

Item # **FL04114**

**Fletcher 2200 Series Mat Cutters**



Change blades quickly with blade magazines. Cuts bevels, straight and v-grooves with a precision head that glides on ball bearings along a polished steel shaft and stainless steel strips for increased stability.

Item # **FL04681** 48" cutting capacity  
 Item # **FL04682** 60" cutting capacity

**Fletcher Measuring Stop for 2200**



• Includes upper and lower stops.

Item # **FL04622**

**Fletcher Right Squaring Extension for 2200**



• Right squaring extension provides a rigid guide for accurate sizing of large mat board.

Item # **FL04630**

**Fletcher 3000 Series Cutting Machine**



The 3000 meets all of your frame shop needs. The spring-loaded, triple-turret cutting assembly has a patented roller design and three cutting tools. The turret device makes it easy to switch from scoring and breaking out glass or plastic to cutting matboard and even foam board up to 1/4" thick.

Item # **FL04711** 48" cutting capacity  
 Item # **FL04712** 60" cutting capacity

**Fletcher Measuring Stop for 3000 & 8400**



• Recommended for production cutting used with 3000 and 8400 series.

Item # **FL04112**

**Fletcher Glass Cutter Wheel**



• Wheel Replacement for 01-275, 8448, 8460, F-3000, SCB-36 & CircleMates, 05-320.

Item # **FL02120** 10 Per Pack

**Fletcher Mat Blades for Fletcher 3000**



• Replacement blade for Fletcher 3000.  
 • Cuts mat board, foam board and gator board.

Item # **FL05003** 100 Per Pack

**Fletcher Plastic Blades for F3000 & F3100**



• Plastic cutting blade for Fletcher 3000 & 3100 series wall cutters.

Item # **FL05712**

**Fletcher Mat Blades for Fletcher 3100**



• Mat board cutting blade for Fletcher 3100.  
 • Cuts mat board, foam board and gator board.

Item # **FL05004**

**We are a full line Fletcher Distributor  
 Please call to inquire about products that  
 are not shown.**



**Sprayway Glass Cleaner**



- Cleans in seconds.
- Guaranteed to leave no film or streaks.
- Removes dirt, grime, and adhesive residue.
- Non-caustic; non flammable.
- Non-ammonia formula dries fast.
- Meets C.A.R.B. (California Air Resource Board) standard for VOC emissions.

**Item #**      **Size**  
**SP50**            19 Oz.

**Sprayway Plastic Cleaner**



- Formulated for use on many surfaces including acrylics, Plexiglass, glass and marble.
- Repels finger smudges, dirt and dust.
- Anti-static, Anti-fog. Fast drying.
- Non-streaking. Easy to use.

**Item #**      **Size**  
**SP848**            19 Oz.

**#1 Novus Acrylic Cleaner**



- Gently cleans all plastics without scratching.
- Leaves a lustrous shine that resists fogging, repels dust, and eliminates static.

**Item #**      **Size**  
**NPC10**            8 Oz.

**#2 Novus Acrylic Scratch Remover**



- Removes fine scratches, haziness and abrasions from most plastics.
- Removes the damage instead of filling it in.
- Buffs out quickly.

**Item #**      **Size**  
**NPC20**            8 Oz.

**#3 Novus Deep Scratch Repair**



- Removes heavy scratches and abrasions from most acrylic surfaces.
- Use when damage is too severe to be restored with NOVUS No. 2 polish.

**Item #**      **Size**  
**NPC30**            8 Oz.

**Novus 2oz. Starter Kits**



- Remove fine scratches, abrasions, haziness and scratches from plastic.
- **KIT INCLUDES:** Novus #1 Plastic Cleaner, Novus #2 Fine Scratch Remover, Novus #3 Heavy Scratch Remover and two Novus Polish Mate Cloths.

**Item #**      **Size**  
**NPC7136**            2 Oz.



**Omega V-Nails**

- All are precision manufactured for reliability and ease of use.

**FOR PISTORIUS MACHINES**

<u>Item #</u>	<u>Size</u>	<u>Description</u>	<u>QTY/Box</u>
VN2000	1/4"-7mm	Soft Wood	6,000
VN2001	1/4"-7mm	Hard Wood	6,000
VN2002	3/8"-10mm	Soft Wood	6,000
VN2003	3/8"-10mm	Hard Wood	6,000
VN2004	1/2"-12mm	Soft Wood	6,000
VN2005	1/2"-12mm	Hard Wood	6,000
VN2006	5/8"-15mm	Soft Wood	6,000
VN2007	5/8"-15mm	Hard Wood	6,000

**FOR PUTNAM/AMP MACHINES**

<u>Item #</u>	<u>Size</u>	<u>Description</u>	<u>QTY/Box</u>
VN3000	1/4"-7mm	Soft Wood	6,000
VN3001	1/4"-7mm	Hard Wood	6,000
VN3002	3/8"-10mm	Soft Wood	6,000
VN3003	3/8"-10mm	Hard Wood	6,000
VN3004	1/2"-12mm	Soft Wood	6,000
VN3005	1/2"-12mm	Hard Wood	6,000
VN3006	5/8"-15mm	Soft Wood	6,000
VN3007	5/8"-15mm	Hard Wood	6,000

**FOR CASSESE MACHINES**

<u>Item #</u>	<u>Size</u>	<u>Description</u>	<u>QTY/Box</u>
VN4000	1/4"-7mm	Soft Wood	1,650
VN4001	1/4"-7mm	Hard Wood	1,650
VN4002	3/8"-10mm	Soft Wood	1,650
VN4003	3/8"-10mm	Hard Wood	1,650
VN4004	1/2"-12mm	Soft Wood	1,650
VN4005	1/2"-12mm	Hard Wood	1,650
VN4006	5/8"-15mm	Soft Wood	1,650
VN4007	5/8"-15mm	MDF Wood	1,650

**Pistorius Brand Vee Nails**

<u>Item #</u>	<u>Size</u>	<u>Description</u>	<u>QTY/Box</u>
VN1000	1/4"-7mm	Soft Wood	5,000
VN1001	1/4"-7mm	Hard Wood	5,000
VN1002	1/4"-7mm	MDF Wood	5,000
VN1003	3/8"-10mm	Soft Wood	5,000
VN1004	3/8"-10mm	Hard Wood	5,000
VN1005	3/8"-10mm	MDF Wood	5,000
VN1006	1/2"-12mm	Soft Wood	5,000
VN1007	1/2"-12mm	Hard Wood	5,000
VN1008	1/2"-12mm	MDF Wood	5,000
VN1009	5/8"-15mm	Soft Wood	2,500
VN1010	5/8"-15mm	MDF Wood	2,500

**Zinc Plated Screw Eyes**

*Short Shank Screw Eyes*



*Long Shank Screw Eyes*



Short Shank Screw Eyes

	200	1000
<u>Size</u>	<u>Per Box</u>	<u>Per Box</u>
217-1/2	H142	H143
216-1/2	H144	H145
215-1/2	H146	H147
214-1/2	H148	H149
213-1/2	H150	H151
212-1/2	H152	H153
211-1/2	H154	H155
210-1/2	H156	H157

Long Shank Screw Eyes

	200	1000
<u>Size</u>	<u>Per Box</u>	<u>Per Box</u>
216	H158	H159
214	H160	H161
212	H162	H163

**Picture Hooks Polybagged with goodwill message**

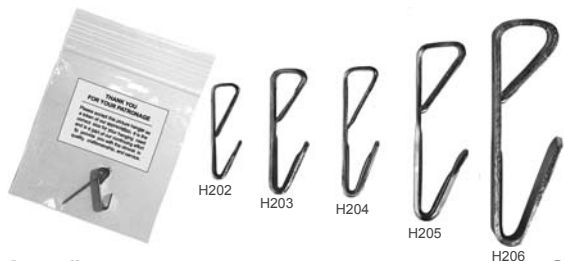

<u>Item #</u>		<u>Qty</u>
H202	10 lb Hook w/ Courtesy Polybag	100
H203	20 lb Hook w/ Courtesy Polybag	100
H204	30 lb Hook w/ Courtesy Polybag	100
H205	50 lb Hook w/ Courtesy Polybag	100
H206	100 lb Hook w/ Courtesy Polybag	100

**Picture Hooks (Bulk)**

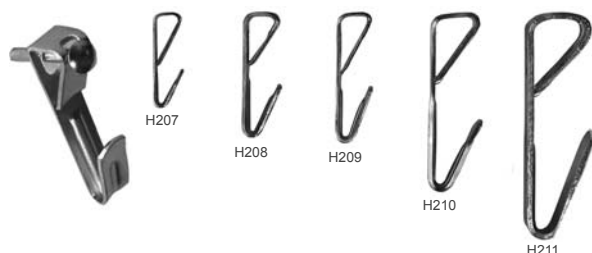

<u>Item #</u>		<u>Qty</u>
H207	10 lb Hook Bulk Packed	1,000
H208	20 lb Hook Bulk Packed	1,000
H209	30 lb Hook Bulk Packed	1,000
H210	50 lb Hook Bulk Packed	1,000
H211	100 lb Hook Bulk Packed	1,000

**T Screw Security Hangers**

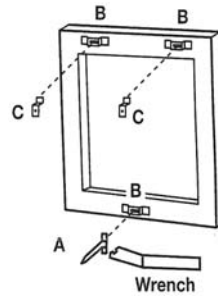

- Security Hangers include special brackets that attach to the frame, wall brackets, and a special T-headed screw which locks into the slotted security plate. Polybag and bulk set contain all parts needed for proper security installation.

**Security Hangers for wood frames:**

- Item #**  
**H136** Poly Bag for 1 Frame.  
**H138** Bulk Set for a 100 Frames

**Security Hangers for metal frames:**

- Item #**  
**H137** Poly Bag parts for 1 Frame.  
**H139** Bulk Set for a 100 Frames

**Security Hardware packaged individually**  
**Wall Support Bracket**



- Item #**  
**H228** 10 - Per Polybag

**T Screws**



- Can be used with Z- Cleat system.
- Item #**  
**H227** 10 - Per Polybag

**Slotted Security Plate**



- Can be used with Z-Cleat system.
- Item #**  
**H229** 10 - Per Polybag

**Plastic Anchors for T-Screws**



- Plastic wall anchors for Item H227 T-Screws.
- Item #**  
**H230** 10 - Per Polybag

**Plastic Wall Anchors for #10 Screws**



- Plastic wall anchors for H192 #10 x 1" screws.
- Item #**  
**H231** 10 - Per Polybag

**Security Wrench**



- Locking Wrench used for locking and unlocking T Screw Security Hangers.
- Item #**  
**H140** Security Wrench 7"  
**H141** Security Wrench 9 1/2"

**Super Hangers**

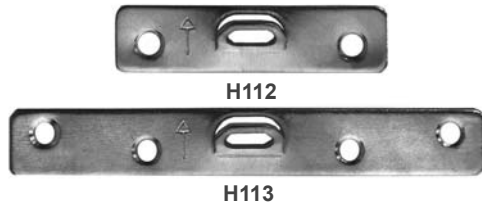

Screw support above and below the wire loop insures it won't pull out of softer woods. Staggered holes reduce risk of splitting the frame.

Item #	Description	Qty
H112	Super Steel 2 hole hgr w/screw	100
H113	Super Steel 4 hole hgr w/screw	100

**Wood Screws**

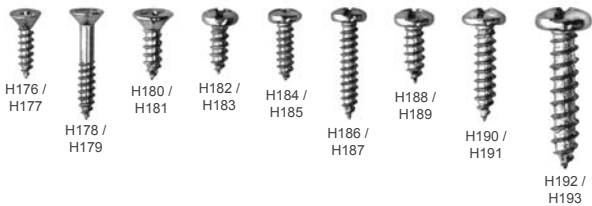

	1000 Per Pack	200 Per Pack
4 X 1/2" Phillips Flat Head wood	H176	H177
4 X 3/4" Phillips Flat Head wood	H178	H179
6 X 1/2" Phillips Flat Head wood	H180	H181
6 X 3/8" Pan Head combo	H182	H183
6 X 1/2" Pan Head combo	H184	H185
6 X 3/4" Pan Head combo	H186	H187
8 X 1/2" Pan Head combo	H188	H189
8 X 3/4" Pan Head combo	H190	H191
10X 1" Pan Head combo	H192	H193

**Z Bar Cleat Hanging Hardware**



Designed to hang large, oversized, and heavy objects. Available in two weights: Regular for under 90 lbs and Super for over 90 lbs. Can be used with security hardware H227, H229 and H230 for a fast, easy to install security hanging solution.

Item #	Description	Qty
HZ1224	12" Regular Z Bar	24 pieces
HZ1224H	12" Heavy Z Bar	24 pieces
HZ2412	24" Regular Z Bar	12 pieces
HZ2412H	24" Heavy Z Bar	12 pieces
HZ368	36" Regular Z Bar	8 pieces
HZ368H	36" Heavy Z Bar	8 pieces
HZ486	48" Regular Z Bar	6 pieces
HZ486H	48" Heavy Z Bar	6 pieces
HZ96	58" Regular Z Bar	20 pieces
HZ96H	58" Heavy Z Bar	20 pieces

**Super-Soft Strand**



- High-strength, corrosion resistant stainless steel.
- Super-soft, flexible protective vinyl jacket protects your fingers and is easy to twist.

Item #	Size	Max. Picture Weight	Approx. Ft. Per Spool
WPS201	2	15 lbs	1,500'
WPS301	3	20 lbs	1,125'
WPS401	4	25 lbs	850'
WPS501	5	43 lbs	500'
WPS601	6	60 lbs	275'
WPS801	8	100 lbs	125'

**Braided Picture Wire**



- Braided Wire is made of heavy-duty galvanized steel.

Item #	Size	Max. Picture Weight	Approx. Ft. Per Spool
WPB201	2	12 lbs	1,500'
WPB301	3	16 lbs	1,025'
WPB401	4	20 lbs	910'
WPB501	5	24 lbs	740'
WPB601	6	28 lbs	650'
WPB801	8	36 lbs	500'

**Wire Caddy**



- For holding 5lb. spools of galvanized braided wire.
- Center feed keeps wire on spools.
- Holds all gauges.

Item #	WC1000
--------	--------

**Offset Clips**

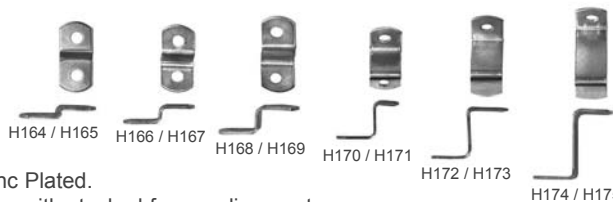

- Zinc Plated.
- Use with stacked frames, liners, etc.

	100 Qty/Box	1,000 Qty/Box
1/8" - 2 hole	H164	H165
1/4" - 2 hole	H166	H167
3/8" - 2 hole	H168	H169
1/2" - 2 hole	H170	H171
3/4" - 1 hole	H172	H173
1" - 1 hole	H174	H175

**Strap Hangers**



	200 Qty/Box	1000 Qty/Box
1 Hole Strap Hanger 1 1/8"	H101	H100
1 Hole Strap Hanger 1 1/4"	H103	H102
1 Hole Strap Hanger 1 7/8"	H105	H104
1 Hole Strap Hanger Wide 1 3/4"	H107	H106
2 Hole Strap Hanger Wide 2 1/8"	H109	H108
3 Hole Strap Hanger Wide 3 3/4"	H111	H110

**Metal Frame Hardware**

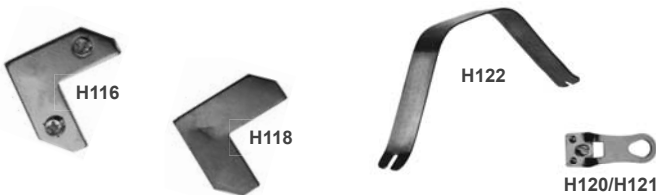

Item #	Description	Qty
H116	Standard Tapped Corner	1000
H118	Back Plates	1000
H120	Euro Hangers	1000
H121	Euro Hangers	200
H122	3/8" Standard Spring Clip	1000
H124	Euro Hangers Bulk Set/100 Frames	
	• Includes enough hardware for 100 frames.	
	Standard Tapped Corner	400 Pcs.
	Back Plates	400 Pcs.
	Euro Hangers	400 Pcs.
	3/8" Standard Spring Clip	800 Pcs.
	Bumpers	400 Pcs.
H125	Euro Hangers in Polybag	
	• Includes enough hardware for 100 frames.	
	Standard Tapped Corner	4 Pcs.
	Back Plates	4 Pcs.
	Euro Hangers	4 Pcs.
	3/8" Standard Spring Clip	8 Pcs.
	Bumpers	4 Pcs.

**Wire Brads**



Item #	Description	
H194	3/4" x 18	Bright 1 lb box
H195	1" x 17	Bright 1 lb box
H196	1" x 19	Bright 1 lb box
H197	1 1/4" x 17	Bright 1 lb box
H198	1 1/2" x 16	Bright 1 lb box
H199	1 1/2" x 18	Bright 1 lb box
H200	1 3/4" x 17	Bright 1 lb box
H201	2" x 16	Bright 1 lb box

**Corner Angles**

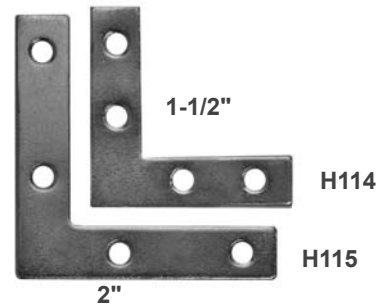

Item #	Description	Qty
H114	Corner angle 1 1/2"	100
H115	Corner angle 2"	100

**Sawtooth Hangers**

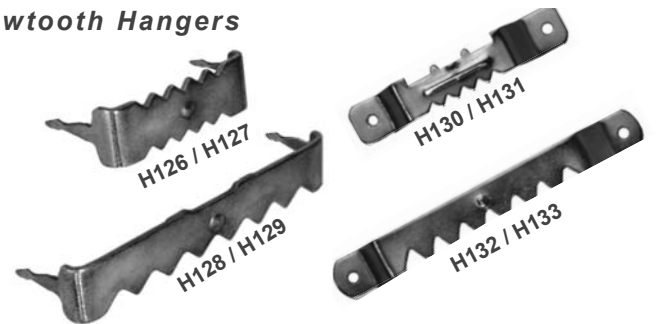

Item #	Description	Qty
H127	7/8" Nailless Sawtooth Gold	100
H129	1 3/4" Nailless Sawtooth Gold	100
H131	1 3/4" Short Steel Sawtooth w/ Nails	100
H133	2 5/8" Long Steel Sawtooth w/ Nails	100
H126	7/8" Nailless Sawtooth Gold	1000
H128	1 3/4" Nailless Sawtooth Gold	1000
H130	1 3/4" Short Steel Sawtooth w/ Nails	1000
H132	2 5/8" Long Steel Sawtooth w/ Nails	1000

**Nailless Sawtooth Insert Tool**



- Magnetized for ease of application.
- One piece steel construction for extended heavy duty use.
- Visible guideline easily centers 7/8" to 1 3/4" long hangers.

Item # H134

**Replacement Blades**

- Can be used on Dexter, Logan, Alto and others.



- Item #**  
**BL1010** #3 - Dexter 5 pack.  
**BL1011** #3 - Dexter 100 pack.

**Retractable Utility Knife**



- Use with blades BL1005 & BL1006.
- Item # BL1012**

**Snap and Retractable Knife**



- Plastic 8 point snap blade knife with one 8 point blade.
- Item # BL1013**

**Snap off Blades**



- Blades are for use with #BL1013.
  - 10 Blades per package.
- Item # BL1014**

**Xacto Black Gripster Knife With Safety Cap**



- Cuts Paper, plastic, balsa, thin metal, cloth, film and acetate.
  - Rear blade release for easy, safe replacement.
  - Rubberized barrel for comfort and control with a anti-roll design.
- Item # BFX3627**

**#11 Blade for X-Acto Knife**



- #11 Blades for BFX3627.
  - Oxidized for rust resistance.
  - 5 Blades per package.
- Item # BFX211**

**Professional Trimming Tool**



- Comes with 5 blades.
  - Exposed blade fits into a molded tract that allows for maximum finger protection & superior eyesight lines for the cleanest, most convenient trimming of backing paper.
- Item # H135**

**Xacto Board Cutter**



- Cuts foam board, mat board, and illustration board.
  - 90 degree and parallel cuts to 9/16" deep.
- Item # BFX7747**

**Premium Mat Cutter Blades - Made in USA**

- Blades for Fletcher and C&H Mat Cutters.



- Item #**  
**BL1000** #1200SE - .012 Gauge Single Edge for regular mat board. 100 per pack.



- Item #**  
**BL1001** #1200 - .012 Gauge For regular mat board. 100 per pack.

- Item #**  
**BL1002** #1500SE - .015 Gauge For Rag Board, Double Thick and 8 ply Rag. 100 per pack.

- Item #**  
**BL1003** #1500 - .015 Gauge For Rag Board, Double Thick and 8 ply Rag. 100 per pack.

**Logan Style Blades**



- Logan Style 270.
  - Fits Cutters #: 301, 301S, 401, 700S, 700SGM, 701, 760SGM, 1000, 2000, 3000 and 4000.
- Item #**  
**BL1004** 1 1/2" x .012 (100 pack)

**Utility Blades**



- Item #**  
**BL1005** .017 thick -100 per pack.

- Item #**  
**BL1006** .025 heavy duty - 100 per pack.

**#9 Single Edge Razor Blade**



- 100 per box.
- Item # BL1007**

**#12 Single Edge Razor Blade**



- 100 per box.
- Item # BL1008**

**#12 Single Edge No Notch**



- 100 per box.
- Item # BL1009**

**Sprayway Fast Tack Mist Adhesive**



- Comparable to Super 77.
- General purpose high performance mist adhesive. Used for both temporary and permanent bonds.
- Non-Staining Formula.

Item #	Size
SP87	13 Oz.

**Sprayway Fast Tack Specialty Adhesive**



- Comparable to Spray Mount.
- Non-Staining / Non Transferable.
- Repositionable adhesive.

Item #	Size
SP89	13 Oz.

**Sprayway Waterproof Matte Fixative**



- Perfect for artists and picture framers and print shops. Provides clear, permanent, waterproof protection for pastels, charcoal, pencil, chalk, ink, watercolors, and casein.
- Will not alter technique or affect even the finest art paper.

Item #	Size
SP204	11 Oz.

**Elmer's Repositionable Mounting Spray**



- Light tack in seconds. Dries clear. Ideal for use with projects where short term adhesion is needed.

Item #	Size
BFE454	10 Oz.

**Elmer's Extra-Strength Mounting Spray**



- Extra Strength Spray Adhesive for permanent bond. No bleed through.
- Strong Tack. Dries Clear.

Item #	Size
BFE456	10 Oz.

**Bienfang® Finish Guard™ UV Laminating Materials**



- Finish Guard™ Heat-activated over laminating films feature UV protection and a low bonding temperature (200°F).
- Films can be applied with Bienfang® Mechanical or Vacuum Press.

*Not for use in the Bienfang® Roller Press.*

**Lustre Rolls** - Provides a highlighted, sparkling finish that is glare-free.

Item #	Size
BF1307	41" x 50'

**Satin-Matte Rolls** - Enhances artwork with a soft, non-reflective finish.

Item #	Size
BF1306	41" x 50'

**Canvas Rolls** - Recreates the rich feel and texture of artist canvas.

Item #	Size
BFH1671	41" x 50'

**Bienfang® Release Paper**



- A reusable, protective overlay made of smooth white paper coated with silicone.
- Protects your drymount press, platen and artwork from adhesive residues.

**Coated - Both Sides**

Item #	Size
BF929	26" x 60'
BF934	42" x 90'

**Coated - One Side**

Item #	Size
BFA490	42" x 90'

**Bienfang® BufferMount®**

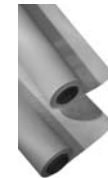

- The safest, most versatile mounting tissue available.
- It is removable and features an alkaline-buffered paper core, acid-free adhesive.
- Low bonding temperature (160-190°F).

Item #	Size
BFH1835	24.5" x 90'
BF1841	40.5" x 90'

**Bienfang® Ragmount**



- Acid free 100% cotton dry mount tissue.
- 100% breathable and bubble preventative
- Low temperature bond (160°F to 190°F)
- Conservation quality.

Item #	Size
BFA435	24.5" x 150' - 1.5" Core
BFA436	40.5" x 150' - 1.5" Core

**Bienfang® ColorMount®**

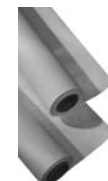

- Permanent, dry mounting adhesive tissue for low temperature bonding (175°F -200°F) of resin-coated photos, glossy posters, and non porous surfaces.

Item #	Size
BF614	24.5" x 150'
BF618	40.5" x 150'
BF622	48.5" x 150'

**Bienfang® Fusion® 4000**

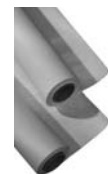

- Clear 100% adhesive - no tissue core.
- Specialized processing creates the cleanest, purest adhesive film available. Fusion 4000 flows easily and evenly under heat (170°F) and solves the problem of mounting fabrics and other textured surfaces. Can be overlapped.

Item #	Size
BF356	24.5" x 90'
BF358	40.5" x 90'

**Bienfang® Sponge Foam Overlay**



- Recommended to ensure an even finish on laminating materials.

Item #	Size
BF1309	42" x 8.5'

**Bienfang® Release Boards**

- Bienfang® Release Boards are durable, reusable, silicone-coated on both sides.
- Increased durability provides easier handling increasing productivity.

**Item #**  
**BF938**      **Size**  
32" x 40" 5 boards

**Filmoplast® P90 Paper Tape**

- White, long-fibered, acid-free, non-aging, wood-free special paper.
- Non-yellowing, permanently elastic acrylate adhesive.

**Item #**  
**N25223**      **Size**  
3/4" x 164'

**Filmoplast® P90 Plus Paper Tape**

- Acid free.
- Self-adhesive special paper, white, free of wood pulp.
- Extra strong adhesive.
- Tear resistant.

**Item #**  
**N6018639**      **Size**  
3/4" x 164'

**Filmoplast® SH Linen Tape**

- Acid-free, fine-threaded, white textile tape.
- PH neutral acrylate adhesive.
- Ideal for hinging mat board onto acid free board when conservation framing.

**Item #**  
**N25124**      **Size**  
1 1/4" x 82'

**Clear Polypropylene Mounting Corners**

- Holds light to moderate weight prints, photos and documents without adhesives ever coming in contact with artwork.
- Allows for expansion and contraction of art within the frame. Artwork can always be removed, and remains in original condition.
- Available in 1 1/4" and 3".

**Item #**  
**L5330035**      1 1/4" 250/pkg  
**L5330037**      3" 100/pkg

**Gummed Linen Tape**

- Water activated tape with 65/55 thread count fabric provides superior hanging strength.
- Neutral pH adhesive has high tack.
- Used for hinging mats and heavy artwork.

**Item #**  
**L5331050**      **Size**  
1" x 150'

**Hayaku Gummed Japanese Hinging Paper**

- Japanese Mulberry Paper coated with acid-free water activated adhesive.
- Used for archival hinging of fine works on paper.

**Item #**  
**L5330752**      **Size**  
1" x 100'

**Abaca Self Adhesive Paper Hinging Tape**

- Eco-friendly paper uses no acid and is easily biodegradable.
- Fibers are three times the strength of cotton.
- Use for hinging prints, posters, photography, and other medium weight works on paper.

**Item #**  
**L5330754**      **Size**  
7/8" x 150'

**Linen Hinging Tape - Self-Adhesive**

- Suited for mat hinging as well as for hinging heavy pieces of artwork.

**Item #**  
**L5331015**      **Size**  
1 1/4" x 400"

**Acid-Free Gummed Linen Hinging Tape**

- Artists and framers rely on linen tape for hinging artwork onto back boards.
- Acid free linen tape with water activated adhesive on back for easy use.
- Will not adhere to plastic or glass.

**Item #**  
**L5331025**      **Size**  
1" x 360"

**See-Thru Archival Mounting Strips**

- Mylar strips hold artwork in place securely around its edges to provide a hingeless and adhesive-free solution for fine art and valuable pieces.
- A necessity for conservation picture framers.

**Item #**  
**L5334015**      **Size**  
4" - 60 / PK

**Self-Adhesive Archival Hinging Tissue**

- Used for mounting light or thin papers where a hinge may show through.
- Neutral pH acrylic adhesive won't turn yellow with age.

**Item #**  
**L5330125**      **Size**  
1" x 400"

**Self-Adhesive Volara Rabbit Foam Tape**



- Self-adhesive acid free foam tape protects canvas transfers, digital art and other media from sticking to wood rabbit.

**Item #**  
**L0181436**      1/4" x 108'

**Corrosion Intercept Frame Sealing Tape**



- Archival quality sealing tape is durable, flexible, and puncture resistant.
- Corrosive Intercept© shields work from outside acids, damaging gases, mildew, and mold.

**Item #**  
**L0342000**      1 1/4" x 85'

**Foil Back Frame Sealing Tape**

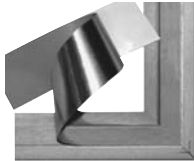

- Seals off raw wood rabbets and fillets to protect the art and seals filler boards to frame.
- Aluminum provides a barrier that stops acid migration.

**Item #**  
**L3870151**      1 1/4" x 1000"

**Acid-Free Buffered Frame Backing Paper**

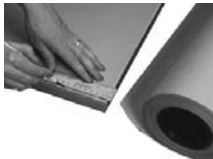

- Acid free - lignin free.
- Protects your framed picture from dust with conservation quality frame backing paper.
- Moderate porous surface allows the frame to breathe readily, assures that adhesives will grip securely, and shrinks well.
- Distinctive blue-gray color denotes archival quality.

**Item #**  
**L6130037**      36" x 300'

**Bienfang® Vacuglue® 300**



- Premium-quality, pH neutral, acid-free, water-soluble mounting adhesive. Applied with brush, roller, spray gun. For use by hand or in cold vacuum mounting frame.

**Item #**  
**BF461**      64oz. Bottle

**Bienfang® Platen Cleaner**



- A paste compound that removes adhesive from press platens.

**Item #**  
**BF935**      2 fl. oz. Jar with pad

**Black Felt Tape**



- Black felt with adhesive backer.
- Acid Free adhesive.
- Great for lining inside of a shadow box.
- Make easel backs fit more frame sizes.
- Great for a variety of creative framing projects.

**Item #**  
**T108**      1" wide roll  
**T109**      1.5" wide roll

**Acid Free ATG Tape**



- Acid Free adhesive.
- Comparable to 3M Gold ATG.
- Standard core fits ATG applicator guns.
- Ideal for adhering mats, mounting artwork, attaching dust covers and many other conservation applications where a permanent bond is preferred.

**Item #**  
**ATG90832**      1/2" x 32 yds

**Standard ATG Tape**



- Ideal for double matting, mounting photos, and artwork where two adhesive surfaces are required.
- Standard core fits ATG applicator guns.
- Comparable to 3M 924 ATG.

**Item #**  
**ATG92436**      1/2" x 36yd  
**ATG92460**      1/2" x 60yd

**Super Tack ATG Tape**



- Clear in color and has a very aggressive permanent Hot Melt Rubber adhesive system, which does not allow repositioning.
- Standard core fits ATG applicator guns.
- Comparable to 3M 969 ATG.

**Item #**  
**ATG96936**      1/2" x 36yds

**Fillet ATG Tape**



- Double-sided polyester tape with an acid-free, acrylic system.
- Acts as a barrier to help prevent acid transfer from the wooden fillet to the mount.

**Item #**  
**ATGF54**      1/4" x 54 yds

**Bumpers**



<u>Item #</u>	<u>Description</u>	<u>Qty</u>
<b>H212</b>	Clear Round	1,000
<b>H213</b>	Clear Round for Metal	1,000
<b>H214</b>	White Round	1,000
<b>H215</b>	Black Round	1,000
<b>H216</b>	Brown Round	1,000

**Natural Crepe Masking Tape**

- Good adhesion on variety of substrates.
- Flexible and easy to use.
- Resists water and oils.
- 3 inch core.

**Item #**  
**T102** 3/4' x 60 yd  
**T103** 1" x 60 yd

**Black 3/4" Crepe Masking Tape**

- Black crepe masking tape with natural rubber adhesive adheres well to many surfaces. Great for a variety of framing applications.
- 3 inch core.

**Item #**  
**T106** 3/4" x 60 yd

**Kraft Flat Back Paper Tape**

- High tack thermoplastic rubber adhesive general purpose paper tape.
- Great for fitting frame backs on contract jobs.
- 3 inch core.

**Item #**  
**T104** 2" x 60 yd

**White Flat Back Tape**

- Smooth white paper finish.
- Constructed of a heavy duty kraft flat back paper coated with a high tack rubber-based adhesive.
- 3 inch core.

**Item #**  
**T105** 1" x 60 yd

**Black 3/8" Mirror Tape**

- Applied to frame rabbet when fitting mirrors to prevent unwanted reflections.
- 3 inch core.

**Item #**  
**T107** 3/8" x 60 yd

**3M™ Super 77™ Multipurpose Adhesive**

- Multipurpose adhesive is an extremely versatile, fast-drying adhesive that bonds a wide range of lightweight materials.

**Item #**  
**3MS77** 16.5 oz. Can

**3M 700 ATG Dispenser Yellow**

- Holds both 1/2" or 3/4" ATG tape.
- A must-have for any frameshop.
- The fastest, cleanest, most convenient way to apply ATG tapes.

**Item #** 3M700

**ATG Dispenser**

- Economical version of the 3M 700.
- Holds both 1/2" or 3/4" ATG tape.
- Easy to load. Easy to use.

**Item #** T100

**3M™ 924 Adhesive Transfer Tape**

- All purpose adhesive bonds to a wide variety of materials such as metals, glass, wood and most framing materials.
- Ideal for bonding mat boards, foam boards etc.

**Item #**  
**3M92412** 1/2 in x 36 yd.  
**3M92434** 3/4 in x 36 yd.

**3M™ 908 "Gold" Acid Free Transfer Tape**

- Adhesive bonds to a wide variety of materials.
- Ideal for conservation framing applications.
- Quick initial tack.
- A must for quality framing jobs.

**Item #**  
**3M90812** 1/2 in x 36 yd.  
**3M90834** 3/4 in x 36 yd.

**3M™ 969 Adhesive Transfer Tape**

- Heavy duty ATG tape.
- Ideal for applications where aggressive adhesive is required.
- Works well uncommon materials such as fabrics and other non paper framing applications.

**Item #**  
**3M96918** 1/2 x 18 yd.  
**3M96936** 1/2 x 36 yd.

**3M™ Photo Mount™ Spray Adhesive**

- Developed for mounting all types of black-and-white or color photographs, 3M™ Photo Mount™ Spray Adhesive is photo safe, strong, clear and non-staining.

**Item #**  
**3MSPM** 10.3 oz. Can

**Chartpak Touch-Up Markers**



- Permanent color. Blends easily to create perfect color matches.
- Conceal join lines on new frames, or cover scratches and chips on old.
- Markers sold individually, and in sets.

<b>Item #</b>	<b>Color</b>	<b>Item #</b>	<b>Color</b>
CPFTM4	Ultra Marine	CPFTM82	Crimson
CPFTM5	True Blue	CPFTM85	Maroon
CPFTM6	Prussian Blue	CPFTM86	Red Mahogany
CPFTM20	Evergreen	CPFTM90	Wine Red
CPFTM29	Leaf Green	CPFTM99	Black
CPFTM42	Cadmium Yellow	CPFTM105	Ice Blue
CPFTM54	Dark Walnut	CPFTM122	Grass Green
CPFTM58	Dark Oak	CPFTM139	Lt.Oak/Maple
CPFTM60	Walnut Mahogany	CPFTM148	Lt.Pine
CPFTM69	Dark Cherry	CPFTM160	Salmon
CPFTM70	Med. Oak		
CPFTM74	Med.Cherry	CPFTMO	Blender

**Touch-Up Marker Sets**

<b>Item #</b>	
CPFTM9	9 pc. Set - Wood Tones
CPSETSF	25 pc. Set - Wood Tone & Color Markers plus Caddy

**Rub N' Buff**



- Fine metallic powders and pigments combined with carnauba wax.
- Apply with finger, soft cloth, or fine brush for touch-ups or embellishments.

<b>Item #</b>	<b>Description</b>	
RNB76361	Golf Leaf	.5oz.
RNB76362	Antique Gold	.5oz.
RNB76363	Olive Gold	.5oz.
RNB76365	Chinese Red	.5oz.
RNB76366	Antique White	.5oz.
RNB76368	Spanish Copper	.5oz.
RNB76369	Ebony	.5oz.
RNB76370	Silver Leaf	.5oz.
RNB76371	Grecian Gold	.5oz.
RNB76372	Autumn Gold	.5oz.
RNB76374	Sapphire	.5oz.
RNB76375	Jade	.5oz.
RNB76379	European Gold	.5oz.
RNB76380	Pewter	.5oz.

**Brush'n Leaf**



- Goes on easily with one application.
- Brush on almost any clean, dry surface such as metal, wood and plastic.
- Non tarnishing.

<b>Item #</b>	<b>Description</b>	
BNL76630	Golf Leaf	1oz.
BNL76631	Antique Golf	1oz.
BNL76632	Silver Leaf	1oz.

**Nail Hole Filler**



- A pliable filler for cracks, crevices and nail holes.
- Will not dry out or shrink.
- Available in 2 oz. tins or 1 lb. jars.

<b>Color</b>	<b>2 OZ.</b>	<b>1 LB.</b>
Orange	NHF21408	NHF21458
Yellow	NHF21409	n/a
Turquoise	NHF21410	n/a
Walnut	NHF21411	NHF21461
Natural	NHF21412	NHF21462
Red	NHF21413	NHF21463
Green	NHF21414	NHF21464
Blue	NHF21415	NHF21465
Mahogany	NHF21416	NHF21466
Ivory	NHF21417	NHF21467
Black	NHF21418	NHF21468
White	NHF21419	NHF21469
Light Oak	NHF21420	NHF21470
Blonde Maple	NHF21421	NHF21471
Red Maple	NHF21422	n/a
Dk Prov Maple	NHF21423	NHF21473
Dark Walnut	NHF21424	NHF21474
Medium Maple	NHF21425	NHF21475
Grey	NHF21426	NHF21476
Gold	NHF21427	NHF21477
Silver	NHF21428	NHF21478
Dark Gold	NHF21429	NHF21479

**Easel Back - Faux Leather Finish**



- Sturdy construction.
- Can be trimmed. Stands vertically or horizontally.
- Size indicates inside dimension of frame.

<b>Item #</b>		
EB46	4 x 6	6 Per Pack
EB57	5 x 7	6 Per Pack
EB810	8 x 10	6 Per Pack
EB1114	11 x 14	6 Per Pack

**Easel Back - Velour Finish**



- Sturdy construction.
- Can be trimmed. Stands vertically or horizontally.
- Attractive flocced velvet surface.
- Size indicates inside dimension of frame.

<b>Item #</b>		
EBV46	4 x 6	6 Per Pack
EBV57	5 x 7	6 Per Pack
EBV810	8 x 10	6 Per Pack
EBV1114	11 x 14	6 Per Pack

**Easel Back - Velour Finish with Door**



- Premium easel back with hinged door used for gift frames and high-end projects.
- 6 per pack.

<b>Item #</b>	<b>Outside</b>	<b>Door</b>
EBVD46	5 5/8 x 7 5/8	4 x 6
EBVD57	6 1/2 x 8 1/2	5 x 7
EBVD810	10 3/8 x 12 3/8	8 x 10
EBVD1114	13 3/8 x 16 3/8	11 x 14

**Miter Magic™ Polyvinyl Glue**

- Special formulation - The strongest glue for joining wood frames available in the industry.
- Dries fast and clear.
- Water soluble for easy clean up.

**Item #**  
**GL100** Pint  
**GL200** Gallon

**Framers Glue**

- General purpose polyvinyl white glue.
- Thinner viscosity, can be used in automatic glue applicators.
- Dries fast and clear.
- Water soluble for easy cleanup.

**Item #**  
**GL500** Pint  
**GL600** Gallon

**All Purpose Mounting Glue**

- Premium-quality, ph neutral, acid-free, water-soluble mounting adhesive. Applied with brush, roller, spray gun, for use by hand or in cold vacuum mounting press.

**Item #**  
**GL400** Gallon

**Fletcher 8" Glass Cutter Pliers**

- Plastic anvil for accurate alignment with score line for easy breakout.
- Can be used for nibbling and shaping corners of glass, tile or plastic.

**Item #** FL06112

**Fredrix® Canvas Pliers**

- Extra wide sure-grip serrated jaws.
- Heavy duty chrome plated steel.
- Spring return handle.

**Item #** CP7400

**Fredrix® Premier Canvas Pliers**

- Premium tool for professionals who demand the best.
- Made of chrome finished metal.
- Rubberized handles.
- Non-slip rubberized jaw that won't damage the canvas.

**Item #** CP7401

**Dusting Brush**

- Traditional design made of soft, sterilized 100% horsehair, wax-set in durable 14 1/2" handle.

**Item #** DB100

**Burnishing Bone**

- Helps clean up and conceal overcuts by making them less visible.
- Eliminates rough edges. 6" long.

**Item #** N37325

**Cotton Gloves**

- For handling delicate items of value.
- Protects subject matter from fingerprints.
- One size fits all.

**Item #** CG1200

**Tape Measure**

- Omega's 16' x 3/4" center finding retractable tape measure.

**Item #** UST1

**Bienfang® UnStik™**

- A special releasing solvent used to remove art work from various mounting adhesives and to clean adhesive residue off artwork or press parts.

**Item #**  
**BF470** 32 fl. oz. can

**Sprayway Lint & Dust Remover**

- Convenient for cleaning small objects and hard to reach places.
- Removes dust from fitted pictures.
- Safe on all electronic equipment.
- Non-Flammable.

(Cannot ship by Air Freight)

**Item #** SP805  
**Size** 10 Oz.

**Z-Gel Gloss**



- This one-step texturing process is a great alternative to canvas transfers.
- Eliminates the need for glass.

<b>Item #</b>	
<b>ZG32G</b>	32oz.
<b>ZG64G</b>	64oz

**Z-Gel Semi Gloss**



- The one step texturing process for posters, prints, and photography.
- Semi gloss finish for a more subtle texture effect.

<b>Item #</b>	
<b>ZG32S</b>	32oz.
<b>ZG64S</b>	64oz.

**Z-Crackle Antiquing Starter Kit**



Contains 16 oz. containers Z-Crackle Finish Step 1 & Step 2 Activator, 2 oz. container of Antiquing Polish, and 6 Pack of 2" foam applicators.

<b>Item #</b>	<b>ZCKIT</b>
---------------	--------------

**RabbitSpace**

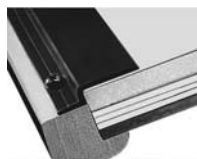

- RabbitSpace is a pH neutral plastic rabbit depth extender used on the back of wood picture frames to extend the depth of shallow rabbets.

<b>Item #</b>	
<b>FRS-1</b>	1/8" 7 x 5' Per pack
<b>FRS-2</b>	1/4" 7 x 5' Per pack
<b>FRS-3</b>	3/8" 7 x 5' Per pack
<b>FRS-4</b>	1/2" 7 x 5' Per pack

**EconoSpace**

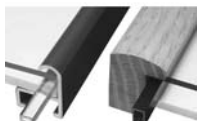

- Creates a space between the artwork and glass.
- Neutral pH - No plasticizers.
- Works in both wood and metal frames.
- Self adhesive. Available in clear and black.

<b>Item #</b>	<b>Description</b>
<b>FRS-5</b>	Clear - 1/16" 100 per pack
<b>FRS-6</b>	Clear - 1/8" 100 per pack
<b>FRS-7</b>	Black - 1/8" 100 per pack
<b>FRS-8</b>	Clear - 1/4" 100 per pack
<b>FRS-9</b>	Black - 1/4" 100 per pack

**Heavy Duty No- Lint Wipes**



- Strong and soft No-Lint Wipes are durable enough for multiple use, reducing waste and cost.
- Non-abrasive, soft cloth-like feel.
- Great for cleaning glass, acrylics and removal of excess glue and touch-up.
- 950 12 1/2" x 13 1/2" wipes per roll.

<b>Item #</b>	<b>WMA750</b>
---------------	---------------

**Shop Stand for rolls of No- Lint Wipes**



- Sturdy metal floor stand dispenser for rolls of No-Lint Wipes. # WMA750
- Great for production framing environments.

<b>Item #</b>	<b>WMA800</b>
---------------	---------------

**No- Lint Wipes in convenient pull-up box**



- Strong and soft No-Lint Wipes are durable enough for multiple use, reducing waste and cost.
- Non-abrasive, soft cloth-like feel.
- Great for cleaning glass, acrylics and removal of excess glue and touch-up.
- 100 9 1/2" x 17" wipes per box.

<b>Item #</b>	<b>WMA100</b>
---------------	---------------

**Corrugated Sheets**

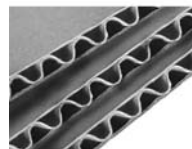

- 200 lbs test.
- For backing, packaging, protection etc.

<b>Item #</b>	<b>Description</b>
<b>CB3240</b>	32" x 40"
<b>CB4064</b>	40" x 64"



**We are a Full Line Pistorius Distributor**

*Please call to inquire about products that are not shown.*



**Corner Protectors**



<u>Item #</u>	<u>Description</u>	<u>Qty</u>
H217	Adjustable Protectors	1,000
H218	3/4" Protectors	1,000
H219	1" Protectors	1,000
H220	Adjustable Protectors	200
H221	2" - 2 3/4" Adjustable	700

**Bubble Wrap**



<u>Item #</u>	<u>Description</u>
PM100	Large Bubble Wrap 24" x 250'
PM101	Large Bubble Wrap 48" x 250'
PM102	Small Bubble Wrap 24" x 500'
PM103	Small Bubble Wrap 48" x 500'

**Foam Padding**



<u>Item #</u>	<u>Description</u>
PM106	36"x 3/32 x 750'/Roll
PM107	24" x 3/32 x 750'/Roll
PM108	12" x 3/32 x 750'/Roll

**Bubble with Kraft Backer**

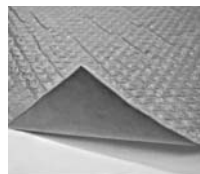

- Convenient all-in-one kraft paper wrap with bubble wrap padding perforated for easy tear off to quickly make folded corner protectors for frames.

<u>Item #</u>	<u>Description</u>
PM109	6" X 250'

**Box Sealing Tape**



- Adhesive sticks to virtually any surface.
- Long shelf live. Meets UPS and US postal specifications.

<u>Item #</u>	<u>Description</u>
T101	2" x 110 Yd Clear"

**5" Shrink Film**



- 80 gauge hand disposable 5" shrink film with cardboard handle.

<u>Item #</u>	<u>Description</u>
PM104	5" 1,000' 80 Gauge

**16" Shrink Film**



- 80 gauge 16" shrink film, rolled.

<u>Item #</u>	<u>Description</u>
PM105	16" 1,500' 80 Gauge

**Plastic Bags**



- 2 mil. thick plastic bags on convenient rolls.
- Ideal for packaging finished framed projects.
- Packed economically - more bags per roll.

<u>Item #</u>	<u>Description</u>	<u>Qty</u>
H222	21" x 25"	300
H223	25" x 35"	180
H224	35" x 44"	100
H225	36" x 48"	90
H226	44" x 64"	55

**Kraft Paper**



- Kraft paper available in brown and black.
- For use as dust covers for backing picture frames, for wrapping projects, protecting packed items, or as interleaving.
- Dispenses on all standard paper roll dispensers/cutters.
- Made from 100% recycled material.

<u>Item #</u>	<u>Description</u>
KP1540	Brown 40lb - 15"
KP3640	Brown 40lb - 36"
KP3650	Brown 50lb - 36"
KP4050	Brown 50lb - 40"
KPB2450	Black 50lb - 24"
KPB3650	Black 50lb - 36"

**Kraft Paper Vertical Dispenser**



- Designed for practical, efficient holding, dispensing, and cutting of roll paper.
- Roll changes can be made quickly by pulling the straight edge blade to an open position and locking into place.
- Holds up to 9" diameter rolls on 3" spool.

<u>Item #</u>	<u>Description</u>
KPD48V	

**Kraft Paper Dispenser**



- Designed to provide years of maintenance free operation.
- Cuts evenly, using either side of the double edged, spring-loaded straight-edge.
- Available in a variety of sizes.

<u>Item #</u>	<u>Description</u>
KPD18	18" Dispenser
KPD24	24" Dispenser
KPD36	36" Dispenser
KPD40	40" Dispenser
KPD48	48" Dispenser

PETERBORO **MATBOARDS**

**CONSERVATION MATBOARD**

- \* White alpha cellulose core that is free of acid, lignin, ground wood and chemical impurities.
- \* Fade and bleed resistant surface papers.
- \* Buffered to an alkaline pH.
- \* Contains no optical brighteners.

**Conservation Matboard 32" x 40"**

<b>A109</b>	TV Black	<b>A454</b>	Nickel
<b>A150-153</b>	White Wash / Cream	<b>A456</b>	Mocha
<b>A211</b>	Dijon	<b>A457</b>	Silver Grey
<b>A215</b>	Talc	<b>A458</b>	Dark Grey
<b>A217</b>	Thistle	<b>A460</b>	Soft Grey
<b>A218</b>	Lichen	<b>A461</b>	Limoges
<b>A219</b>	Balsam	<b>A462</b>	Cedar
<b>A220</b>	Fathom	<b>A463</b>	Taupe
<b>A221</b>	Peregrine	<b>A464</b>	Art Brown
<b>A222</b>	Azure	<b>A465</b>	Moss Green
<b>A223</b>	Pacific	<b>A466</b>	Cadet Grey
<b>A224</b>	Sahara	<b>A468</b>	Blueberry
<b>A225</b>	Sierra	<b>A470</b>	White
<b>A226</b>	Saffron	<b>A471</b>	Agate Grey
<b>A227</b>	Ash	<b>A472</b>	Chalk
<b>A228</b>	Smoke	<b>A473</b>	Venetian Blue
<b>A230</b>	Cinnamon	<b>A476</b>	Silver Pine
<b>A231</b>	Apple Red	<b>A478</b>	Juniper
<b>A232</b>	Peach	<b>A479</b>	Soft White
<b>A233</b>	Lavender	<b>A480</b>	Beaver Brown
<b>A403</b>	Goldenrod	<b>A481</b>	Bisque
<b>A405</b>	Evergreen	<b>A482</b>	Plum
<b>A406</b>	Cardinal Red	<b>A485</b>	Trail
<b>A407</b>	Mist	<b>A486</b>	Dark Black
<b>A408</b>	Bluejay	<b>A488</b>	Maize
<b>A410</b>	Winter White	<b>A489</b>	Porpoise
<b>A411</b>	Silver White	<b>A491</b>	Riviera Blue
<b>A412</b>	Burgundy	<b>A492</b>	Antique
<b>A414</b>	Forest Green	<b>A494</b>	Coral
<b>A415</b>	Terrace	<b>A495</b>	Ivory
<b>A416</b>	Putty	<b>A496</b>	Pale Blue
<b>A417</b>	Cirrus	<b>A499</b>	Burnt Sienna
<b>A423</b>	Atlantic	<b>A501</b>	Feather Grey
<b>A426</b>	Tan	<b>A502</b>	Charcoal Grey
<b>A427</b>	Sapphire	<b>A504</b>	Teakwood Black
<b>A431</b>	Pumice	<b>A819</b>	Dark Blue
<b>A432</b>	Flax	<b>A4000</b>	Antique Rose
<b>A434</b>	Raspberry	<b>A4001</b>	Oatmeal
<b>A435</b>	Sand	<b>A4002</b>	Cashew
<b>A438</b>	Haze	<b>A4003</b>	Caribbean Blue
<b>A440</b>	Spring Green	<b>A4004</b>	Antique Blue
<b>A441</b>	Pecan	<b>A4005</b>	Pink
<b>A442</b>	Cognac	<b>A4006</b>	Olive
<b>A443</b>	Coffee	<b>A4007</b>	Ice Pink
<b>A444</b>	Rosewood	<b>A4008</b>	Blush
<b>A445</b>	Rust	<b>A4009</b>	Celery
<b>A446</b>	Storm Grey	<b>A4010</b>	Soft Mauve
<b>A448</b>	Powder Blue	<b>A4011</b>	Victorian Rose
<b>A449</b>	Off White	<b>A4012</b>	Beige
<b>A451</b>	Sunflower	<b>A4013</b>	Pearl
<b>A452</b>	Snow	<b>A4014</b>	Glacier White
<b>A453</b>	Pale Grey		

**Embossed Conservation 32" X 40"**

<b>A160</b>	White Eggshell
<b>A161</b>	Light Cream Eggshell
<b>A1304</b>	Black Linen
<b>A1350</b>	Linen White
<b>A1401</b>	Pebbled White
<b>A1409</b>	Pebbled Black

**Conservation 32" X 40" Double Thick**

<b>A452-DT</b>	Snow
<b>A470-DT</b>	White
<b>A472-DT</b>	Chalk
<b>A504-DT</b>	Teakwood Black

**Conservation 40" X 60"**

<b>AG6150-6153</b>	White Wash / Cream	<b>AG6465</b>	Moss Green
<b>AG6217</b>	Thistle	<b>AG6468</b>	Blueberry
<b>AG6224</b>	Sahara	<b>AG6470</b>	White
<b>AG6231</b>	Apple Red	<b>AG6472</b>	Chalk
<b>AG6406</b>	Cardinal Red	<b>AG6473</b>	Venetian Blue
<b>AG6410</b>	Winter White	<b>AG6479</b>	Soft White
<b>AG6412</b>	Burgundy	<b>AG6504</b>	Teakwood Black
<b>AG6414</b>	Forest Green	<b>AG64001</b>	Oatmeal
<b>AG6434</b>	Raspberry	<b>AG64002</b>	Cashew
<b>AG6438</b>	Haze	<b>AG64010</b>	Soft Mauve
<b>AG6449</b>	Off White	<b>AG64012</b>	Beige
<b>AG6452</b>	Snow	<b>AG64013</b>	Pearl
<b>AG6464</b>	Art Brown	<b>AG64014</b>	Glacier White

**Conservation 40" X 60" Double Thick**

<b>AG6452-DT</b>	Snow
<b>AG6504-DT</b>	Teakwood Black

# PETERBORO **MATBOARDS**

## REGULAR MATBOARD

- \* Easy to cut cream core for smooth, crisp bevels.
- \* Buffered to a pH of 8.2 +/- .5% to neutralize acid.
- \* Extra heavy surface papers that resist tearing while cutting.

### Regular 32" x 40"

<b>R101-109</b> Smooth White	<b>R343</b> Coffee
<b>R111</b> Dijon	<b>R344</b> Rosewood
<b>R113</b> Citrus	<b>R345</b> Rust
<b>R115</b> Talc	<b>R346</b> Storm Grey
<b>R117</b> Thistle	<b>R348</b> Powder Blue
<b>R118</b> Lichen	<b>R349</b> Off White
<b>R119</b> Balsam	<b>R351</b> Sunflower
<b>R120</b> Fathom	<b>R352</b> Snow White
<b>R121</b> Peregrine	<b>R353</b> Pale Grey
<b>R122</b> Azure	<b>R354</b> Nickel
<b>R123</b> Pacific	<b>R356</b> Mocha
<b>R124</b> Sahara	<b>R357</b> Silver Grey
<b>R125</b> Sierra	<b>R358</b> Dark Grey
<b>R126</b> Saffron	<b>R359</b> Claret
<b>R127</b> Ash	<b>R360</b> Soft Grey
<b>R128</b> Smoke	<b>R361</b> Limoges
<b>R131</b> Apple Red	<b>R362</b> Cedar
<b>R132</b> Peach	<b>R363</b> Taupe
<b>R133</b> Lavender	<b>R364</b> Art Brown
<b>R150-153</b> White & Cream	<b>R365</b> Moss Green
<b>R160</b> White Eggshell	<b>R366</b> Cadet Grey
<b>R161</b> Light Cream	<b>R368</b> Blueberry
<b>R303</b> Goldenrod	<b>R369</b> Sparkling White
<b>R305</b> Evergreen	<b>R370</b> White
<b>R306</b> Cardinal Red	<b>R371</b> Agate Grey
<b>R307</b> Mist	<b>R372</b> Chalk
<b>R308</b> Bluejay	<b>R373</b> Venetian Blue
<b>R309</b> Brite White	<b>R374</b> Pale Lemon
<b>R310</b> Winter White	<b>R375</b> Chinese Red
<b>R311</b> Silver White	<b>R376</b> Silver Pine
<b>R312</b> Burgundy	<b>R377</b> Maroon
<b>R314</b> Forest Green	<b>R378</b> Juniper
<b>R315</b> Terrace	<b>R379</b> Soft White
<b>R317</b> Cirrus	<b>R380</b> Beaver Brown
<b>R319</b> Dark Blue	<b>R381</b> Bisque
<b>R320</b> Crimson	<b>R382</b> Plum
<b>R321</b> Crystal White	<b>R385</b> Trail
<b>R322</b> Vanilla	<b>R386</b> Dark Black
<b>R323</b> Atlantic	<b>R388</b> Maize
<b>R327</b> Sapphire	<b>R389</b> Porpoise
<b>R331</b> Pumice	<b>R391</b> Riviera Blue
<b>R332</b> Flax/Lin	<b>R392</b> Antique
<b>R334</b> Raspberry	<b>R394</b> Coral
<b>R335</b> Sand	<b>R395</b> Ivory
<b>R338</b> Haze	<b>R396</b> Pale Blue
<b>R339</b> Cocoa	<b>R399</b> Burnt Sienna
<b>R340</b> Spring Green	<b>R401</b> Feather Grey
<b>R341</b> Pecan	<b>R402</b> Charcoal Grey
<b>R342</b> Cognac	<b>R404</b> Teakwood Black

### Designer Regular

<b>R1411</b>	29.5 X 40	Lace
<b>R1412</b>	32 X 40	Khaki
<b>R1414</b>	29.5 X 40	Gold
<b>R1416</b>	29.5 X 40	Curio
<b>R1419</b>	29.5 X 40	Black Leather
<b>R1420</b>	32 X 40	Onyx
<b>R1450</b>	32 X 40	Butterscotch

### Textured and Embossed Regular 32" x 40"

<b>R251-259</b>	Pebbled White
<b>R1304</b>	Teakwood Black Linen
<b>R1350</b>	Linen White
<b>R1353</b>	Linen India Tint
<b>R1369</b>	Linen Sparkling White
<b>R1401-1409</b>	Pebbled Wt/ Blk

### Regular Foils 32" x 40"

<b>R781</b>	Smooth Gold
<b>R782</b>	Light Gold
<b>R762</b>	Gold Foil
<b>R791</b>	Mercury
<b>R792</b>	Gold Foil
<b>R793</b>	Light Silver

### Regular 40" x 60"

<b>RG6117</b>	Thistle
<b>RG6124</b>	Sahara
<b>RG6150-6153</b>	White & Cream
<b>RG6312</b>	Burgundy
<b>RG6314</b>	Forest Green
<b>RG6338</b>	Haze
<b>RG6364</b>	Art Brown
<b>RG6365</b>	Moss Green
<b>RG6368</b>	Blueberry
<b>RG6369</b>	Sparkling White
<b>RG6370</b>	White
<b>RG6373</b>	Venetian Blue
<b>RG6404</b>	Teakwood Black

PETERBORO **MATBOARDS**

**WHITECORE MATBOARD**

- \* Buffered to a pH of 8.0 to 9.5.
- \* Bright white bevel.
- \* Wide range of colors.

**Whitecore 32" x 40"**

<b>W101-109</b>	Smooth White & Black
<b>W503</b>	Goldenrod
<b>W505</b>	Evergreen
<b>W506</b>	Cardinal Red
<b>W507</b>	Mist
<b>W508</b>	Bluejay
<b>W509</b>	Brite White
<b>W510</b>	Winter White
<b>W511</b>	Silver White
<b>W512</b>	Burgundy
<b>W514</b>	Forest Green
<b>W515</b>	Terrace
<b>W516</b>	Putty
<b>W517</b>	Cirrus
<b>W519</b>	Dark Blue
<b>W520</b>	Crimson
<b>W521</b>	Crystal White
<b>W522</b>	Vanilla
<b>W523</b>	Atlantic
<b>W526</b>	Tan
<b>W527</b>	Sapphire
<b>W531</b>	Pumice
<b>W532</b>	Flax
<b>W534</b>	Raspberry
<b>W535</b>	Sand
<b>W538</b>	Haze
<b>W539</b>	Cocoa
<b>W540</b>	Spring Green
<b>W541</b>	Pecan
<b>W542</b>	Cognac
<b>W543</b>	Coffee
<b>W544</b>	Rosewood
<b>W545</b>	Rust
<b>W546</b>	Storm Grey
<b>W548</b>	Powder Blue
<b>W549</b>	Off White
<b>W551</b>	Sunflower
<b>W552</b>	Snow White
<b>W553</b>	Pale Grey
<b>W554</b>	Nickel
<b>W556</b>	Mocha
<b>W557</b>	Silver Grey
<b>W558</b>	Dark Grey
<b>W559</b>	Claret
<b>W560</b>	Soft Grey
<b>W561</b>	Limoges
<b>W562</b>	Cedar
<b>W563</b>	Taupe
<b>W564</b>	Art Brown
<b>W565</b>	Moss Green
<b>W566</b>	Cadet Grey
<b>W568</b>	Blueberry
<b>W569</b>	Sparkling White
<b>W570</b>	White
<b>W571</b>	Agate Grey
<b>W572</b>	Chalk
<b>W573</b>	Venetian Blue

<b>W574</b>	Pale Lemon
<b>W575</b>	Chinese Red
<b>W576</b>	Silver Pine
<b>W577</b>	Maroon
<b>W578</b>	Juniper
<b>W579</b>	Matboard Soft
<b>W580</b>	White
<b>W581</b>	Beaver Brown
<b>W582</b>	Bisque
<b>W585</b>	Plum
<b>W586</b>	Trail
<b>W588</b>	Dark Black
<b>W589</b>	Maize
<b>W591</b>	Porpoise
<b>W592</b>	Riviera Blue
<b>W594</b>	Antique
<b>W595</b>	Coral
<b>W596</b>	Ivory
<b>W599</b>	Pale Blue
<b>W601</b>	Burnt Sienna
<b>W602</b>	Feather Grey
<b>W604</b>	Charcoal Grey
<b>W611</b>	Teakwood Black
<b>W613</b>	Dijon
<b>W615</b>	Citrus
<b>W617</b>	Talc
<b>W618</b>	Thistle
<b>W619</b>	Lichen
<b>W620</b>	Balsam
<b>W621</b>	Fathom
<b>W622</b>	Peregrine
<b>W623</b>	Azure
<b>W624</b>	Pacific
<b>W625</b>	Sahara
<b>W626</b>	Sierra
<b>W627</b>	Saffron
<b>W628</b>	Ash
<b>W631</b>	Smoke
<b>W632</b>	Apple Red
<b>W633</b>	Peach
<b>W5000</b>	Lavender
<b>W5001</b>	Antique Rose
<b>W5002</b>	Oatmeal
<b>W5003</b>	Cashew
<b>W5004</b>	Caribbean Blue
<b>W5005</b>	Antique Blue
<b>W5006</b>	Pink
<b>W5007</b>	Olive
<b>W5008</b>	Ice Pink
<b>W5009</b>	Blush
<b>W5010</b>	Celery
<b>W5011</b>	Soft Mauve
<b>W5012</b>	Victorian Rose
<b>W5013</b>	Beige
<b>W5014</b>	Pearl
	Glacier White

**Whitecore 32" X 40" Double Thick**

<b>W521-DT</b>	Crystal White
<b>W569-DT</b>	Sparkling White
<b>W572-DT</b>	Chalk
<b>W604-DT</b>	Teakwood Black

**Whitecore Foils 32" X 40"**

<b>W781</b>	Smooth Gold
<b>W782</b>	Light Gold
<b>W791</b>	Mercury
<b>W792</b>	Gold Foil
<b>W793</b>	Light Silver

**Designer Whitecore**

<b>W1411</b>	29.5 X 40	Lace
<b>W1412</b>	32 X 40	Khaki
<b>W1414</b>	29.5 X 40	Gold
<b>W1416</b>	29.5 X 40	Curio
<b>W1419</b>	29.5 X 40	Black Leather
<b>W1420</b>	32 X 40	Onyx
<b>W1450</b>	32 X 40	Butterscotch

**Whitecore 40" x 60"**

<b>WG6521</b>	Crystal White
<b>WG6552</b>	Snow
<b>WG6569</b>	Sparkling White
<b>WG6570</b>	White
<b>WG6604</b>	Teakwood Black
<b>WG65001</b>	Oatmeal
<b>WG65002</b>	Cashew
<b>WG65010</b>	Soft Mauve
<b>WG65012</b>	Beige
<b>WG65013</b>	Pearl
<b>WG65014</b>	Glacier White

**Whitecore 40" X 60" Double Thick**

<b>WG6521-DT</b>	Crystal White
<b>WG6569-DT</b>	Sparkling White
<b>WG6604-DT</b>	Teakwood Black

# PETERBORO **MATBOARDS**

## BLACK CORE MATBOARD

- \* All components are acid free.
- \* Buffered to a pH of 7.5 to 9.5.
- \* Rich even bleed resistant black core.
- \* Easy to cut.

### BLACK CORE 32" x 40"

<b>B118</b>	Lichen
<b>B305</b>	Evergreen
<b>B311</b>	Silver White
<b>B315</b>	Terrace
<b>B353</b>	Pale Grey
<b>B368</b>	Blueberry/Blackcore
<b>B369</b>	Sparkling White
<b>B370</b>	White
<b>B372</b>	Chalk/Craie
<b>B377</b>	Maroon
<b>B378</b>	Juniper
<b>B389</b>	Porpoise
<b>B404</b>	Teakwood Black
<b>B781</b>	Gold
<b>B791</b>	Mercury
<b>B3001</b>	Oatmeal

### BLACK CORE 40" x 60"

<b>BG6369</b>	Sparkling White
<b>BG6370</b>	White
<b>BG6372</b>	Chalk
<b>BG6378</b>	Juniper
<b>BG6404</b>	Teakwood Black
<b>BG6781</b>	Gold

## DESIGNER SILKSCREEN MATBOARD

- \* Printed with light fast bleed resistant inks.
- \* High quality whitecore.
- \* Smooth bright white bevel.

### Designer Silkscreen 32" x 40"

<b>DSK0101</b>	Fresco Chalk	<b>DSK0201</b>	Venetian Plaster Ivory	<b>DSK0302</b>	Travertine Vanilla
<b>DSK0102</b>	Fresco Vanilla	<b>DSK0202</b>	Venetian Plaster Talc	<b>DSK0303</b>	Travertine Haze
<b>DSK0103</b>	Fresco Haze	<b>DSK0203</b>	Venetian Plaster Powder	<b>DSK0304</b>	Travertine Bisque
<b>DSK0104</b>	Fresco Maize	<b>DSK0204</b>	Venetian Plaster Sierra	<b>DSK0305</b>	Travertine Lichen
<b>DSK0105</b>	Fresco Nickel	<b>DSK0205</b>	Venetian Plaster Flax	<b>DSK0306</b>	Travertine Dark Green
<b>DSK0106</b>	Fresco Rosewood	<b>DSK0206</b>	Venetian Plaster Feather Grey	<b>DSK0307</b>	Travertine Pecan
<b>DSK0107</b>	Fresco Juniper	<b>DSK0207</b>	Venetian Plaster Juniper	<b>DSK0308</b>	Travertine Walnut
<b>DSK0109</b>	Fresco Beaver Brown	<b>DSK0208</b>	Venetian Plaster Beaver Brown	<b>DSK0310</b>	Travertine Teakwood
<b>DSK0110</b>	Fresco Teakwood	<b>DSK0209</b>	Venetian Plaster Teakwood	<b>DSK0311</b>	Travertine Nero
<b>DSK0111</b>	Fresco Ebony	<b>DSK0301</b>	Travertine Chalk		

## DESIGNER SUEDE MATBOARD

- \* A high quality designer suede, rich in color with a dense luxurious flock.
- \* Buffered to a pH of 8.0 to 9.5.
- \* Clean extra thick bright white bevel.

### Designer Suede 32" x 40"

<b>DS950</b>	Black Suede	<b>DS958</b>	Buckskin Suede	<b>DS966</b>	Mint Green Suede
<b>DS951</b>	Navy Suede	<b>DS959</b>	Latte Suede	<b>DS967</b>	Mushroom Suede
<b>DS952</b>	Hazelnut Suede	<b>DS960</b>	Chocolate Suede	<b>DS968</b>	Slate Blue Suede
<b>DS953</b>	Moss Green Suede	<b>DS961</b>	Gun Metal Suede	<b>DS969</b>	Gull Grey Suede
<b>DS954</b>	Emerald Suede	<b>DS962</b>	Royal Blue Suede	<b>DS970</b>	White Suede
<b>DS955</b>	Pewter Suede	<b>DS963</b>	Camel Suede	<b>DS971</b>	Pine Suede
<b>DS956</b>	Bordeaux Suede	<b>DS964</b>	Champagne Suede	<b>DS972</b>	Bronze Suede
<b>DS957</b>	Royal Red Suede	<b>DS965</b>	Dove Grey Suede		

PETERBORO **MATBOARDS**



- \* 100% Cotton Fiber.
- \* Solid Color throughout.
- \* Traditional ply construction.
- \* Buffered with calcium carbonate.
- \* Naturally acid and lignin free.



**Museum 32" X 40" 1 ply**

M900-1 White

**Museum 32" X 40" 2 ply**

M900-2 White

**Museum 32" X 40" 4 ply**

M900-4 White  
 M901-4 Warm White  
 M902-4 Traditional White  
 M903-4 Cream  
 M904-4 Light Grey  
 M905-4 Black

**Museum 32" X 40" 8 ply**

M900-8 White  
 M901-8 Warm White  
 M902-8 Traditional White

**Museum 40" X 60" 4 ply**

MG900-4 White  
 MG901-4 Warm White  
 MG902-4 Traditional White  
 MG903-4 Cream  
 MG904-4 Light Grey

**Museum 40" X 60" 8 ply**

MG900-8 White  
 MG901-8 Warm White  
 MG902-8 Traditional White

**MOUNTING BOARDS**

**Paper Lined Mountboards - Buffered**

<b>1092</b>	95 pt	White - Two Sides	40x60
<b>5032</b>	55 pt	White - Two Sides	32x40
<b>5033</b>	95 pt	White - Two Sides	32x40
<b>R265-266</b>	130 pt	Cream & White - Two Sides	32x40

**Grey Unlined Mountboards**

<b>910M</b>	40 pt	Single Thick	32x40
<b>920G</b>	80 pt	Double Thick	40x60
<b>920M</b>	80 pt	Double Thick	32x40

**Peterboro's Quality Guarantee**



As an extra step in our quality control procedures, Peterboro matboard components are regularly sent to independent pulp and paper testing laboratories for analysis. This ensures compliance with FACTS, Fine Art Trade Guild and PPFA matboard standards.

**Fine Art Trade Guild (FATG)**

The Fine Art Trade Guild Mountboard Standards Development Group comprises mountboard manufacturers, distributors and users from across the world, including conservators, who are committed to achieving consensus and compliance for minimum standards of mountboards appropriate for clearly defined levels of framing. The Guild thus provides clear communication to framers and helps them educate consumers on the various quality levels available to protect artwork.

**The Fine Art Care & Treatment Standards**



FACTS was established in 1994 and evolved from the ever-increasing need for information about the preservation of artwork and keepsakes. FACTS standards address their subject with the most current scientific research and the widest possible participation. Peterboro Conservation meets and in many cases exceeds the FACTS guide for Performance in Mat and Mounting Boards. The standards are reviewed regularly to include new research and are recognized by the Professional Picture Framers Association (PPFA).

# THE LIBRARY OF Professional Picture Framing

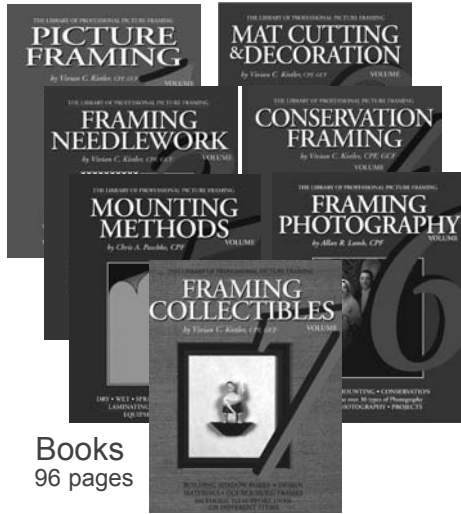

Books  
96 pages

- 1 PICTURE FRAMING B116**  
Cutting, joining moulding, glazing, measuring, mats, mounting equipment, frame design, canvas, conservation.
- 2 MAT CUTTING & DECORATION B019**  
50+ mat cuts. v-grooves, French mats, cover, fabric wrapped, multiple opening, circles, ovals, gothic, fancy cuts.
- 3 FRAMING NEEDLEWORK B027**  
Block, stretch, cleaning, repairs, pressing. Crewel, needlepoint, cross-stitch, antique samplers, quilt, scarf, Persian art & flag.
- 4 CONSERVATION FRAMING B035**  
Art on paper, glazing, hinges, adhesives, boards, encapsulation, deacidification, water-colors, papyrus, pastels, photos, parchment
- 5 MOUNTING METHODS B043**  
Dry, Wet, Spray, Pressure-Sensitive Mounting. Adhesives, boards, equipment, laminating, canvas transfer.
- 6 FRAMING PHOTOGRAPHY B051**  
Framing ambrotype, daguerreotype, albumen, tintype, Ilfochrome Classics®, Polaroid®, snapshots and more! Mounting photos. Projects. Creative framing cases.
- 7 FRAMING COLLECTIBLES B299**  
Building shadow boxes, design, materials, double-sided frames, attachments & methods to support 120+ items. Hinged boxes.

## DVDs

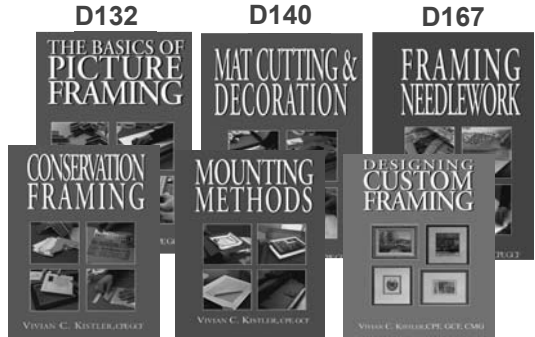

**D132 D140 D167**  
**D175 D698 D701**  
One hour videos demonstrating the most popular methods and techniques.

Featuring  
**VIVIAN KISTLER**  
Master Certified Picture Framer,  
Guild Commended Framer, Adv.



## Quick Smart Series

Concise Information on  
Just the Topic you need.

### QUICK SMART BOOKS

32 page 8.5x11

- Starting A Picture Framing Business **B760**
- Pricing Custom Picture Framing **B876**
- Selling at the Framing Counter **B353**
- Mounting With Clear Film **B23X**  
Jim Miller MCPF, GCF
- Where is Mrs. Smith's Watercolor? **B06X**  
Processing WorkOrders; 14 Different Forms
- FloorPlans for Frame Shops & Galleries **B272**  
Front & backroom plans for from 400 to 4,000 sq.ft.
- How to Build Worktables, Fixtures & Jigs **B361**  
Paul MacFarland CPF, GCF
- Who's The Boss? **B221**  
Hiring & training employees..
- Event Planning & Marketing **B574**  
Boost sales in your gallery or frame shop

## Quick Smart DVDs

Short, to-the-point demonstrations. 15-30 minutes

- Traditional French Matting **D153**  
Ink lines and wash panels
- Cutting &Joining Frames **D146**  
Methods & machines for wood & metal
- Framing Sports Collectibles **D115**  
T-shirt, jersey, ball, puck, locker boxes
- Conservation Hinges **D184**  
T-hinge, pass-through, jumbo and Z-hinge
- Measuring Made Easy **D981**  
Fractions, Reading Rulers, Uneven Border
- Cutting & Installing Fillets **D566**  
A perfect fit in a mat or frame
- Canvas Transfers **D139**  
Two methods of transfers are demonstrated



Frame Shop  
Reference Posters  
Four 11x17 two-color posters:  
•Needlework & Fabric,  
•Hinges & Supports  
•Supporting Collectibles •Mats & Measurements  
**P078**

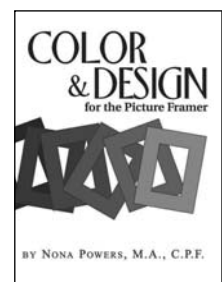
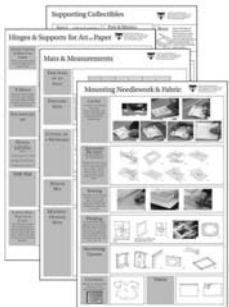

by Nona Powers, MCPF, GCF, BFA Size, color and shape of mats, mouldings and decorative elements. A work-book with practice sheets is included in the back of the book. **B485**

Brian Wolf's Cutting, Carving & Decorating Mats **B85X**

Decorative Accessories Made with Moulding **B604**

